

PENBERTHY®

# Hydraulic Adapter

For use with Tubular Glass Gages

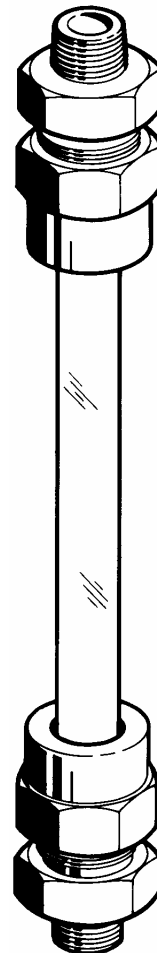

Installation, Operation and Maintenance Instructions

# TABLE OF CONTENTS

<b>Product Warranty</b>	. . . . .	<b>iii</b>
<b>1.0 About the Manual</b>	. . . . .	<b>1</b>
<b>2.0 Introduction</b>	. . . . .	<b>1</b>
<b>2.1 System Description</b>	. . . . .	<b>1</b>
<b>3.0 Available Models</b>	. . . . .	<b>1</b>
<b>3.1 Maximum Pressure/Temperature Ratings</b>	. . . . .	<b>2,3</b>
<b>4.0 Inspection</b>	. . . . .	<b>3</b>
<b>5.0 Installation</b>	. . . . .	<b>3</b>
<b>5.1 Attachment of the Hydraulic Fittings.</b>	. . . . .	<b>4</b>
<b>5.2 Sight Glass Installation</b>	. . . . .	<b>4</b>
<b>6.0 Operation</b>	. . . . .	<b>4</b>
<b>6.1 Pre-Operational Check</b>	. . . . .	<b>4</b>
<b>6.2 Hydrostatic Test</b>	. . . . .	<b>4</b>
<b>6.3 Operation</b>	. . . . .	<b>5</b>
<b>7.0 Maintenance</b>	. . . . .	<b>5</b>
<b>7.1 Preventative Maintenance</b>	. . . . .	<b>5</b>
<b>7.2 Maintenance Procedures</b>	. . . . .	<b>6</b>
<b>8.0 Disassembly - Reassembly</b>	. . . . .	<b>6</b>
<b>8.1 Disassembly</b>	. . . . .	<b>6</b>
<b>8.2 Reassembly</b>	. . . . .	<b>7</b>
<b>9.0 Disposal at End of Useful Life</b>	. . . . .	<b>7</b>
<b>10.0 Telephone Assistance</b>	. . . . .	<b>7</b>
<b>11.0 Exploded Parts Drawing</b>	. . . . .	<b>8</b>

<b>TABLES AND FIGURES</b>		<b>page</b>
Table 1	Available Options. . . . .	1
Table 2	Design Ratings . . . . .	2
Table 3	Tubular Glass Ratings . . . . .	2
Figure 1	Attachment of the Hydraulic Fittings . . . . .	4
Figure 2	Exploded Parts Drawing. . . . .	8

## **PENBERTHY PRODUCT WARRANTY**

Tyco Valves & Controls Prophetstown warrants its Penberthy products as designed and manufactured by TV&C Prophetstown to be free of defects in the material and workmanship for a period of one year after the date of installation or eighteen months after the date of manufacture, whichever is earliest. TV&C Prophetstown will, at its option, replace or repair any products which fail during the warranty period due to defective material or workmanship.

Prior to submitting any claim for warranty service, the owner must submit proof of purchase to TV&C Prophetstown and obtain written authorization to return the product. Thereafter, the product shall be returned to TV&C in Prophetstown, Illinois, with freight paid.

This warranty shall not apply if the product has been disassembled, tampered with, repaired or otherwise altered outside of TV&C Prophetstown factory, or if it has been subject to misuse, neglect or accident.

The responsibility of TV&C Prophetstown hereunder is limited to repairing or replacing the product at its expense. TV&C Prophetstown shall not be liable for loss, damage or expenses related directly or indirectly to the installation or use of its products, or from any other cause or for consequential damages. It is expressly understood that TV&C Prophetstown is not responsible for damage or injury caused to other products, buildings, personnel or property, by reason of the installation or use of its products.

THIS IS TV&C PROPHETSTOWN'S SOLE WARRANTY AND IN LIEU OF ALL OTHER WARRANTIES, EXPRESSED OR IMPLIED WHICH ARE HEREBY EXCLUDED, INCLUDING IN PARTICULAR ALL WARRANTIES OF MERCHANTABILITY OR FITNESS FOR A PARTICULAR PURPOSE.

This document and the warranty contained herein may not be modified and no other warranty, expressed or implied, shall be made by or on behalf of TV&C Prophetstown unless made in writing and signed by the General Manager or Director of Engineering of TV&C Prophetstown.

# INSTALLATION, OPERATION and MAINTENANCE MANUAL FOR PENBERTHY HYDRAULIC ADAPTERS

## 1.0 About the Manual

This manual has been prepared as an aid and guide for personnel involved installation or maintenance. All instructions must be read and understood thoroughly before attempting any installation, operation, or maintenance.

# SAFETY INSTRUCTIONS

Penberthy does not have any control over the manner in which its Hydraulic Adapter is handled, installed, or used, and Penberthy cannot and will not guarantee that the Hydraulic Adapter is suitable or compatible for the user's specific application.



## WARNING

Pressurized fluid streams can unexpectedly exit pipelines or unusual mechanical stresses can cause material failure. Safety glasses should be worn when installing or operating a Hydraulic Adapter. Failure to follow *any* instruction could result in a malfunction of the gagecock with resulting sudden release of pressure, property damage or physical injury.

## 2.0 Introduction

Penberthy's Hydraulic Adapters are intended to be used in place of standard gagecocks. They are supplied as a set (upper and lower connections) and attach to each end of a 5/8" (16 mm) or 3/4" (19 mm) OD sight glass tube. This combination then forms a Tubular Glass Gage.

### 2.1 System Description

The Penberthy Hydraulic Adapter is machined from one of three standard materials: carbon steel, brass, or 316 STS. It provides a 1/2" NPT male connection that allows you to incorporate most standard hydraulic connections currently available. Some of the options available to a gagecock style Tubular Glass Gage can also be used with Hydraulic Adapters.

Guard Rods	Plastic, Glass, or Wire Glass Protector	Sheet Metal Protector	Refractive Protector	Internal Tube
n/a	◆	n/a	◆	n/a

Table 1

## 3.0 Available Models

Penberthy Hydraulic Adapters are available in both 5/8" (16 mm) and 3/4" (19 mm) sight glass tube sizes.

### 3.1 Maximum Pressure/Temperature Ratings

#### DESIGN RATINGS

Body Material	Glass Packing	5/8" (16mm) OD	3/4" (19 mm) OD
1215 Carbon Steel ASTM A108	Grafoil® (Standard)	500 psig [3450 kPaG] at -20°F [ -29°C] to +500°F [260°C]	500 psig [3450 kPaG] at -20°F [ -29°C] to +500°F [260°C]
	Teflon®	500 psig [3450 kPaG] at -20°F [ -29°C] to +500°F [260°C]	500 psig [3450 kPaG] at -20°F [ -29°C] to +500°F [260°C]
	Neoprene®	500 psig [3450 kPaG] at -20°F [ -29°C] to +300°F [149°C]	500 psig [3450 kPaG] at -20°F [ -29°C] to +300°F [149°C]
	Viton®	500 psig [3450 kPaG] at -20°F [ -29°C] to +400°F [204°C]	500 psig [3450 kPaG] at -20°F [ -29°C] to +400°F [204°C]
Brass ASTM B16	Grafoil® (Standard)	200 psig [1380 kPaG] at -325°F [-198°C] to +100°F [ 38°C] 125 psig [ 860 kPaG] at -325°F [-198°C] at +400°F [204°C]	400 psig [2760 kPaG] at -325°F [-198°C] to +100°F [ 38°C] 250 psig [1720 kPaG] at -325°F [-198°C] at +400°F [204°C]
	Teflon®	200 psig [1380 kPaG] at -325°F [-198°C] to +100°F [ 38°C] 125 psig [ 860 kPaG] at -325°F [-198°C] at +400°F [204°C]	400 psig [2760 kPaG] at -325°F [-198°C] to +100°F [ 38°C] 250 psig [1720 kPaG] at -325°F [-198°C] at +400°F [204°C]
	Neoprene®	200 psig [1380 kPaG] at -65°F [-54°C] to +100°F [ 38°C] 165 psig [1140 kPaG] at -65°F [-54°C] at +300°F [149°C]	400 psig [2760 kPaG] at -65°F [ -54°C] to +100°F [ 38°C] 335 psig [2310 kPaG] at -65°F [ -54°C] at +300°F [149°C]
	Viton®	200 psig [1380 kPaG] at -20°F [-29°C] to +100°F [ 38°C] 125 psig [ 860 kPaG] at -20°F [-29°C] at +400°F [204°C]	400 psig [2760 kPaG] at -20°F [ -29°C] to +100°F [ 38°C] 250 psig [1720 kPaG] at -20°F [ -29°C] at +400°F [204°C]
316 STS ASTM A276	Grafoil® (Standard)	500 psig [3450 kPaG] at -325°F [-198°C] to + 500°F [260°C]	500 psig [3450 kPaG] at -325°F [-198°C] to + 500°F [260°C]
	Teflon®	500 psig [3450 kPaG] at -325°F [-198°C] to + 500°F [260°C]	500 psig [3450 kPaG] at -325°F [-198°C] to + 500°F [260°C]
	Neoprene®	500 psig [3450 kPaG] at -65°F [-54°C] to +300°F [149°C]	500 psig [3450 kPaG] at -65°F [ -54°C] to +300°F [149°C]
	Viton®	500 psig [3450 kPaG] at -20°F [-29°C] to +400°F [204°C]	500 psig [3450 kPaG] at -20°F [ -29°C] to +400°F [204°C]

**Table 2**

Pressure/Temperature ratings above are subject to the limitations of the tubular glass utilized. See Table 3.

Pressure/Temperature Ratings For a Single Piece of Tubular Glass (Both 5/8" [16mm] and 3/4" [19 mm])				
CENTER TO CENTER DISTANCE FOR VESSEL CONNECTIONS		NO CORROSION UP TO 150°F		
		High Pressure	Heavy Wall	Red Line
Inches	[mm]	psig [kPaG]	psig [kPaG]	psig [kPaG]
10	[ 254]	410 [2830]	600 [4140]	340 [2340]
15	[ 381]	385 [2650]	600 [4140]	310 [2140]
20	[ 508]	355 [2450]	600 [4140]	285 [1970]
25	[ 635]	300 [2070]	580 [4000]	260 [1790]
30	[ 762]	275 [1900]	550 [3790]	230 [1590]
35	[ 889]	240 [1650]	500 [3450]	200 [1380]
40	[1016]	210 [1450]	420 [2900]	180 [1240]
45	[1143]	200 [1380]	360 [2480]	170 [1170]
50	[1270]	180 [1240]	340 [2340]	160 [1100]
55	[1397]	150 [1030]	N/A	140 [ 970]
60	[1524]	140 [ 970]	N/A	120 [ 830]
65	[1651]	125 [ 860]	N/A	600 [4140]
70	[1778]	600 [4140]	N/A	90 [ 620]

N/A – Not Available

**Table 3**

Using a secured Glass Union and multiple pieces of glass will increase the pressure/temperature rating over that of an equivalent length of single glass.



## DANGER

**Under no circumstances should Hydraulic Adapters be used for steam-water applications. Pressurized steam can not be contained by the hydraulic coupling. Attempting the use of a Hydraulic Adapter in this manner could result in death, physical injury or property damage.**

### 4.0 Inspection

Upon receipt of a Hydraulic Adapter, check all components carefully for damage incurred in shipping. If damage is evident or suspected, do not attempt installation. Notify carrier immediately and request damage inspection.

A typical Penberthy Hydraulic Adapter set consists of (1) upper glass connection and (1) lower glass connection. Each connection contains (1) body, (1) glass packing, (1) glass packing gland, and (1) glass packing nut.

The user should confirm that:

- A. The unit delivered matches the description on the purchase order.
- B. The operating conditions originally described match the actual operating conditions at the installation site.
- C. The actual operating conditions at the installation site are within the design rating for the unit delivered.
- D. The materials of construction for the Hydraulic Adapter delivered are compatible with the conditions at the installation site.

## SAFETY INSTRUCTIONS

**If the size, model, or performance data of the Hydraulic Adapter as received does not conform with any of the criteria above, do not proceed with installation. Contact an authorized Penberthy distributor for assistance. The incorrect adapter can result in unacceptable performance and potential damage to the Tubular Glass Gage.**

### 5.0 Installation

Installation should only be undertaken by qualified personnel who are familiar with this equipment. They should have read and understood all of the instructions in this manual.



## WARNING

**The hydraulic couplings must be securely mounted to the vessel or a stable framework. Failure to follow instructions could result in the separation of the sight glass from the Hydraulic Adapter stuffing box and a sudden release of pressurized fluid causing serious personal injury and property damage.**

## 5.1 Attachment of the Hydraulic Fittings

- A. Connect both the upper and lower adapters to your hydraulic fittings. Use Teflon® tape, or equivalent, on all male pipe threads. See Figure 1.
- B. Tighten connections to a pressure tight joint.

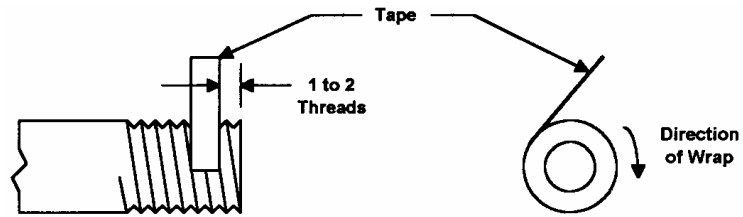

Figure 1

## 5.2 Sight Glass Installation

- A. Loosen both the upper and lower glass packing nuts. Insure there is no compressive force on glass packing.
- B. Move the upper adapter so it is offset from the lower adapter and will allow the sight glass to be inserted.
- C. Insert sight glass up into the upper adapter.
- D. Hold sight glass with upward force to check that it clears the lower adapter. Check vertical alignment of adapters.
- E. Pull sight glass down into the lower adapter until you achieve a positive stop.
- F. Tighten both the upper and lower glass packing nuts.

In some cases it may be necessary to remove glass packing nut, glass packing gland, glass packing, and glass packing retainer and mount them to the sight glass prior to insertion of glass in upper and lower gagecock bodies. See Figure 2, the Exploded Parts Drawing for the proper sequence.

## 6.0 Operation

### 6.1 Pre-Operational Check

Before startup, the operator should assure that:

- A. all installation procedures have been completed.
- B. all connections are pressure tight.

### 6.2 Hydrostatic Test

- A. Take all precautions necessary to handle the possibility of leakage.
- B. Hydrostatic pressure test installation to at least 100 psig (690 kPaG) and correct any leakage before proceeding.

### 6.3 Operation

Tubular Glass Gages should be brought into service slowly to avoid excessive thermal shock or mechanical stress on the tubular glass and potential glass breakage. By introducing the process fluid in this manner you allow the gage temperature and pressure to slowly equalize with the vessel.



**Failure to follow the recommended operating procedures for Tubular Glass Gages can result in the rapid pressurization of the gage assembly. This can cause glass breakage and the sudden loss of pressure. Serious personal injury and property damage can occur.**

### 7.0 Maintenance

Maintenance should only be undertaken by qualified, experienced personnel who are familiar with this equipment and have read and understood all the instructions in this manual.

The user must create maintenance schedules, safety manuals, and inspection details for each specific gage and Hydraulic Adapter installation. These will be based upon the users own operating experience with their specific application. Realistic maintenance schedules can only be determined with full knowledge of the services and application situations involved.



**Do not proceed with any maintenance on a Hydraulic Adapter with the Tubular Glass Gage still at operating pressure or temperature. Relieve the unit of pressure or vacuum, allow it to reach ambient temperature, and purge or drain it of all fluids. Failure to follow instructions could result in the sudden release of pressurized fluid causing personal injury or property damage.**

### 7.1 Preventative Maintenance

On all installations, regularly check the following items:

- A. Adapters, for signs of leakage around hydraulic fitting connections.
- B. Adapters, for signs of leakage around stuffing box connection.
- C. Adapters, for signs of internal or external corrosion.
- D. Sight Glass, for signs of etching or scratching

## 7.2 Maintenance Procedures

- A. Signs of leakage around the hydraulic fitting connections indicates the lack of a pressure tight joint. This can be remedied by tightening the connection or removing and replacing the Teflon® tape on the adapter threads.
- B. Signs of leakage around the stuffing box indicate worn glass packing or improper compression of glass packing. To replace glass packing, follow Disassembly steps 1 through 6 and Reassembly steps 1 through 8. In the event of improper packing compression, leakage can be stopped by tightening glass packing nut.
- C. It is the user's responsibility to choose a material of construction compatible with both the contained fluid and the surrounding atmosphere for the user's specific application. If internal or external corrosion is present, an investigation must immediately be carried out by the user as to the cause of the problem. This includes consulting with an authorized Penberthy distributor.
- D. For broken sight glass replacement, follow Disassembly steps 1, through 6 and Reassembly steps 1 through 8.

**IMPORTANT: New glass packing must be used when replacing glass.**



**Do not proceed with the disassembly if the Tubular Glass Gage is still at operating pressure or temperature. Relieve the unit of pressure or vacuum, allow it to reach ambient temperature, and purge or drain it of all fluids. Failure to comply could result in the sudden release of pressurized fluid causing personal injury or property damage.**

## 8.0 Removal - Disassembly - Reassembly

### 8.1 Disassembly

- 1. Remove protector if present.
- 2. Loosen glass packing nuts on both the upper and lower adapters.
- 3. Slide sight glass into the upper adapter until the sight glass clears the stuffing box connection on the lower adapter.
- 4. While holding the glass in this position, move the upper adapter until clearance for removing the glass from the upper adapter is created.
- 5. Remove the sight glass from the upper adapter.
- 6. Remove the glass packing nut, glass packing gland, glass packing, and glass packing retainer from both the upper and lower adapters.

## 8.2 Reassembly

1. Refer to Figure 2.
2. Prepare for installation of new packing by cleaning all packing chambers and glands of upper and lower adapters.
3. Replace glass packing nut, glass packing gland, glass packing, and glass packing retainer packing on each end of the tubular glass.
4. With the upper adapter offset to create clearance, insert one end sight glass into the upper stuffing box connection. Check to see the other end of the sight glass will clear the lower adapter.
5. Move the upper adapter into alignment with the lower adapter.
6. Slide the sight glass into the lower adapter until you achieve a positive stop.
7. Tighten both glass packing nuts.
8. Replace protector if present.

## 9.0 Disposal at End of Useful Life

Penberthy Hydraulic Adapters are used in a variety of fluid applications. By following the appropriate federal and industry regulations, the user must determine the extent of preparation and treatment the adapter must incur before its disposal. A Material Safety Data Sheet (MSDS) may be required before disposal services accept certain components.

Metal, glass and polymers should be recycled whenever possible. Refer to order and TV&C - Prophetstown Material Specification sheets for materials of construction

## 10.0 Telephone Assistance

If you are having difficulty with your Hydraulic Adapter, contact your local Penberthy distributor. You may also contact the factory direct at (815) 537-2311 and ask for an applications engineer. So that we may assist you more effectively, please have as much of the following information available as possible when you call:

Model #  
Name of the company from whom you purchased your Hydraulic Adapter  
Invoice # and date  
Process conditions (pressure, flow rates, tank shape, etc)  
A brief description of the problem  
Trouble shooting procedures that failed

If attempts to solve your problem fail, you may request to return your adapter to the factory for intensive testing. You must obtain a Return Authorization (R.A.) number from TV&C Prophetstown before returning anything. Failure to do so will result in the unit being returned to you without being tested, freight collect. To obtain an R.A. number, the following information (in addition to that above) is needed:

Reason for return  
Person to contact at your company  
"Ship To" address

There is a minimum charge of \$75.00 for evaluation of non-warranty units. You will be contacted before any repairs are initiated should the cost exceed the minimum charge. If you return a unit under warranty, but is not defective, the minimum charge will apply.

Grafoil® is a registered trademark of Graftech, Inc.  
Neoprene®, Viton®, and Teflon® are registered trademarks of E.I. duPont de Nemours and Company

## 11.0 Exploded Parts Drawing

Recommended Spare Parts		
REF #	ITEM	QTY
34	Packing, Glass	2
35	Retainer, Glass Packing	2
37	Nut, Glass Packing	1
48	Glass	1

11 Body  
34 Packing, Glass  
35 Retainer, Glass Packing  
36 Gland, Glass Packing  
37 Nut, Glass Packing  
48 Glass

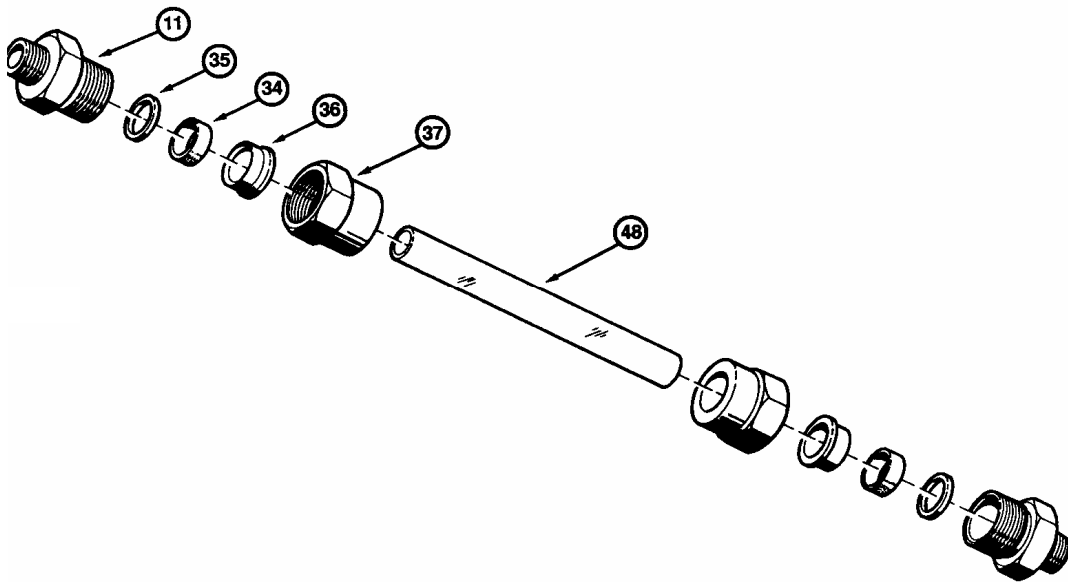

Figure 2



Tyco Valves & Controls, L.P. Prophetstown  
320 Locust St., Prophetstown, Illinois 61277  
Phone: 815-537-2311  
FAX: 815-537-5764  
Printed in USA  
Part No. 18K94-009

© 2005 Tyco Valves & Controls, L.P. Prophetstown, All Rights Reserved