

# PENBERTHY dimensions

Section 2000  
Dimensions 2712.1  
Issued 1/09  
Replaces 07/05

For: **MODEL RH AND RHR GAGE – END CONNECTED**

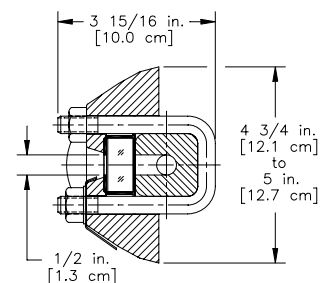
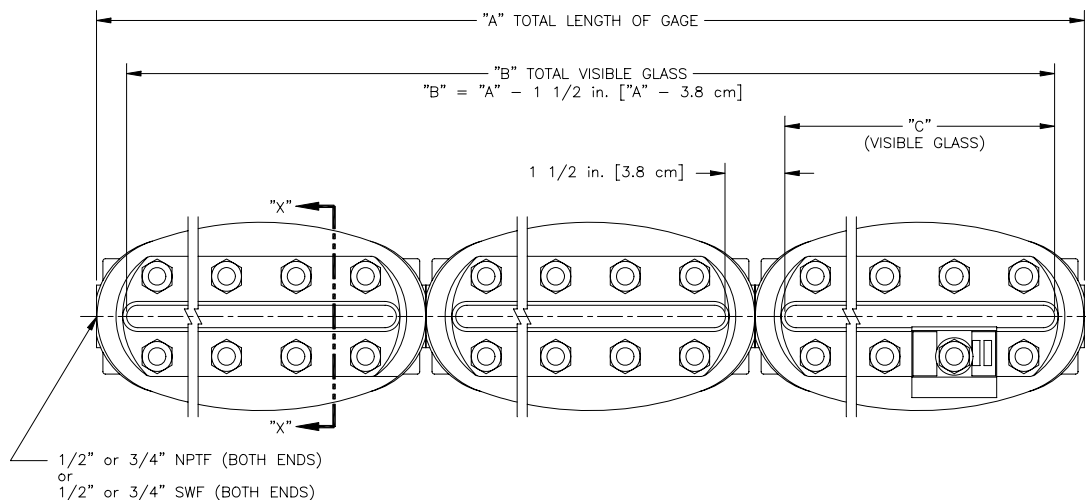

SECTION X-X  
(standard chamber)

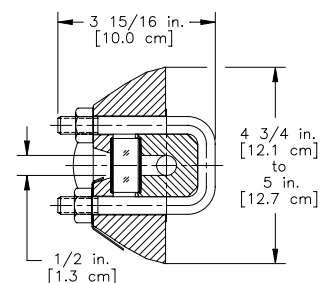

SECTION X-X  
(recessed chamber)

Unit designation is assigned as follows:

Example: 3RH 6H Gage

The first number equals the number of gage sections (3);

the next two letters indicate gage model (RH – Reflex High Pressure);

the last number denotes the glass size (6); the last letter identifies the current design

Glass Size	Dim "C" In Inches & [cm]	Dimension "A" In Inches [cm] Note: For 3/4" NPT and 3/4" SWF Add 3/4 [19] to Dimension "A" on RHR Series ONLY										Quantity Per Section		
		Number of Sections										Bolt	Nut	
		1	2	3	4	5	6	7	8	9	10			
4	6 3/4 [17.1]	8 1/4 [21.0]	16 1/2 [41.9]										4	8
5	7 7/8 [20.0]	9 3/8 [23.8]	18 3/4 [47.6]										5	10
6	9 1/8 [23.2]	10 5/8 [27.0]	21 1/4 [54.0]	31 7/8 [81.0]									6	12
7	10 1/4 [26.0]	11 3/4 [29.8]	23 1/2 [59.7]	35 1/4 [89.5]	47 [119.4]	58 3/4 [149.2]							6	12
8	11 7/8 [30.2]	13 3/8 [34.0]	26 3/4 [67.9]	40 1/8 [101.9]	53 1/2 [135.9]	66 7/8 [169.9]	80 1/4 [203.8]	93 5/8 [237.8]	107 [271.8]	120 3/8 [305.8]	133 3/4 [339.7]		7	14
9	12 5/8 [32.1]	14 1/8 [35.9]	28 1/4 [71.8]	42 3/8 [107.6]	56 1/2 [143.5]	70 5/8 [179.4]	84 3/4 [215.3]	98 7/8 [251.1]	113 [287.0]	127 1/8 [322.9]	141 1/4 [358.8]		7	14

# PENBERTHY dimensions

Section 2000  
Dimensions 2712.2  
Issued 1/09  
Replaces 07/05

For: **MODEL TH AND THR GAGE – END CONNECTED**

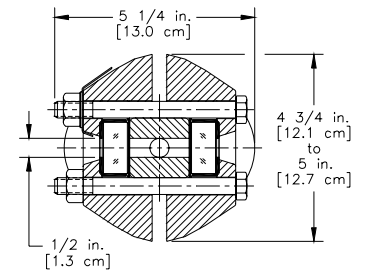
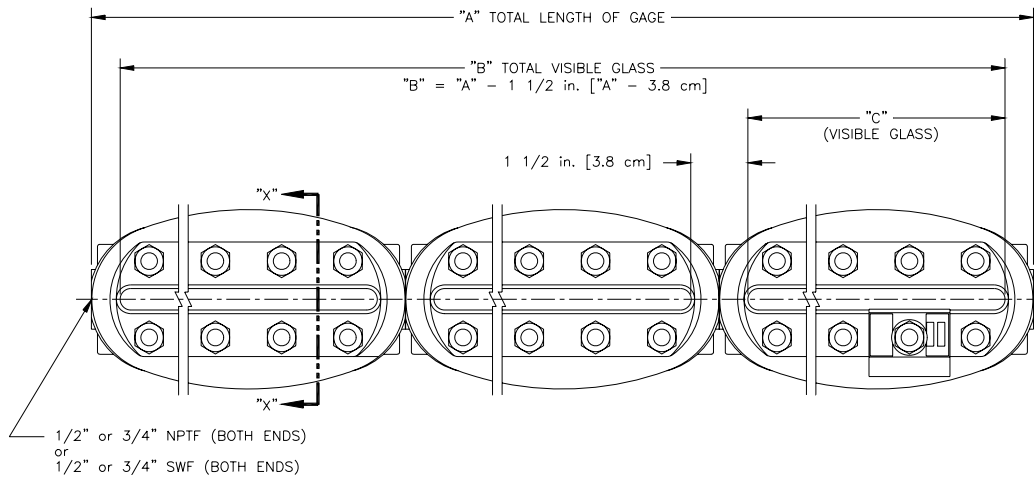

SECTION X-X  
(standard chamber)

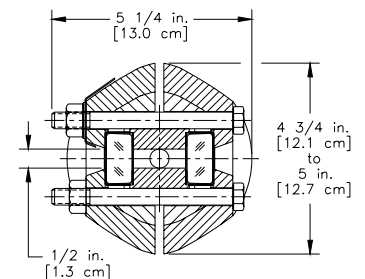

SECTION X-X  
(recessed chamber)

Unit designation is assigned as follows:

Example: 3TH 6H Gage

The first number equals the number of gage sections (3);

the next two letters indicate gage model (TH – Transparent High Pressure);

the last number denotes the glass size (6); the last letter identifies the current design

Glass Size	Dim "C" In Inches & [cm]	Dimension "A" In Inches [cm] Note: For 3/4" NPT and 3/4" SWF Add 3/4 [19] to Dimension "A" on THR Series ONLY										Quantity Per Section		
		Number of Sections										Bolt	Nut	
		1	2	3	4	5	6	7	8	9	10			
4	6 3/4 [17.1]	8 1/4 [21.0]	16 1/2 [41.9]										8	8
5	7 7/8 [20.0]	9 3/8 [23.8]	18 3/4 [47.6]										10	10
6	9 1/8 [23.2]	10 5/8 [27.0]	21 1/4 [54.0]	31 7/8 [81.0]									12	12
7	10 1/4 [26.0]	11 3/4 [29.8]	23 1/2 [59.7]	35 1/4 [89.5]	47 [119.4]	58 3/4 [149.2]							12	12
8	11 7/8 [30.2]	13 3/8 [34.0]	26 3/4 [67.9]	40 1/8 [101.9]	53 1/2 [135.9]	66 7/8 [169.9]	80 1/4 [203.8]	93 5/8 [237.8]	107 [271.8]	120 3/8 [305.8]	133 3/4 [339.7]		14	14
9	12 5/8 [32.1]	14 1/8 [35.9]	28 1/4 [71.8]	42 3/8 [107.6]	56 1/2 [143.5]	70 5/8 [179.4]	84 3/4 [215.3]	98 7/8 [251.1]	113 [287.0]	127 1/8 [322.9]	141 1/4 [358.8]		14	14