

# PENBERTHY

## dimensions

Section 2000  
 Dimensions 2715  
 Issued 07/05  
 Replaces 04/05

For: **MODEL RMW & TMW GAGES**

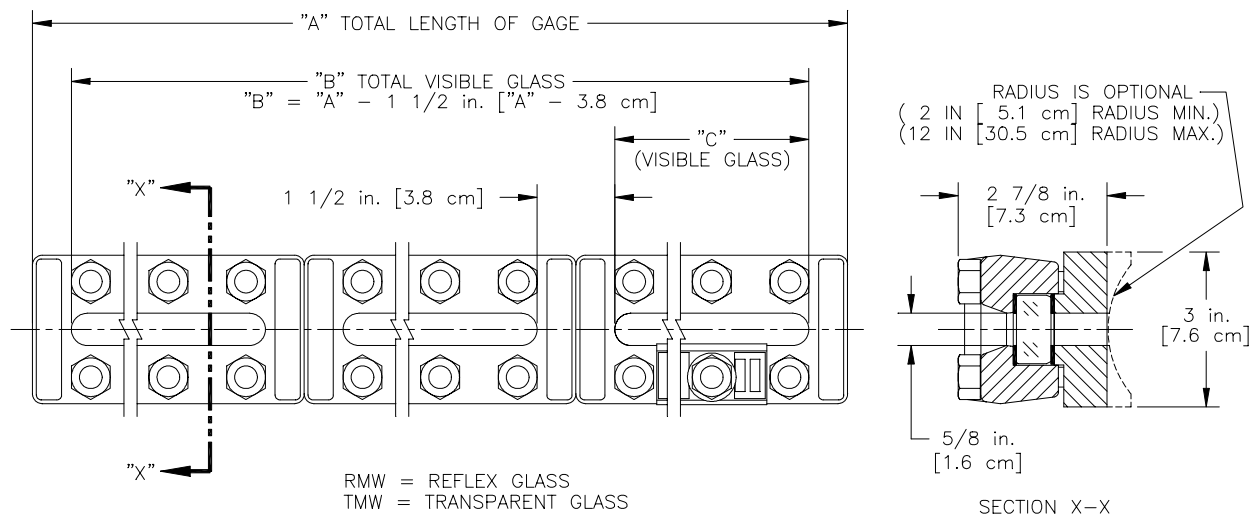

Unit designation is assigned as follows:

Example: 3RMW6

The first number equals the number of gage sections (3);  
 the next three letters indicate gage model (RMW - Reflex Medium Pressure Weld Pad);  
 the last number denotes glass size (6).

Glass Size	Dim "C" In Inches & [cm]	Dimension "A" In Inches [cm]										Quantity Per Section		
		Number of Sections										Stud	Nut	
		1	2	3	4	5	6	7	8	9	10			
1	3 3/4 [9.5]	5 1/4 [13.3]											6	6
2	4 3/4 [12.1]	6 1/4 [15.9]											6	6
3	5 3/4 [14.6]	7 1/4 [18.4]											8	8
4	6 3/4 [17.1]	8 1/4 [21.0]	16 1/2 [41.9]										8	8
5	7 7/8 [20.0]	9 3/8 [23.8]	18 3/4 [47.6]										10	10
6	9 1/8 [23.2]	10 5/8 [27.0]	21 1/4 [54.0]	31 7/8 [81.0]									12	12
7	10 1/4 [26.0]	11 3/4 [29.8]	23 1/2 [59.7]	35 1/4 [89.5]	47 [119.4]	58 3/4 [149.2]							12	12
8	11 7/8 [30.2]	13 3/8 [34.0]	26 3/4 [67.9]	40 1/8 [101.9]	53 1/2 [135.9]	66 7/8 [169.9]	80 1/4 [203.8]	93 5/8 [237.8]	107 [271.8]	120 3/8 [305.8]	133 3/4 [339.7]		14	14
9	12 5/8 [32.1]	14 1/8 [35.9]	28 1/4 [71.8]	42 3/8 [107.6]	56 1/2 [143.5]	70 5/8 [179.4]	84 3/4 [215.3]	98 7/8 [251.1]	113 [287.0]	127 1/8 [322.9]	141 1/4 [358.8]		14	14