

**PENBERTHY®**

# Gage Illuminators

Flat Glass and Magnetic Gage

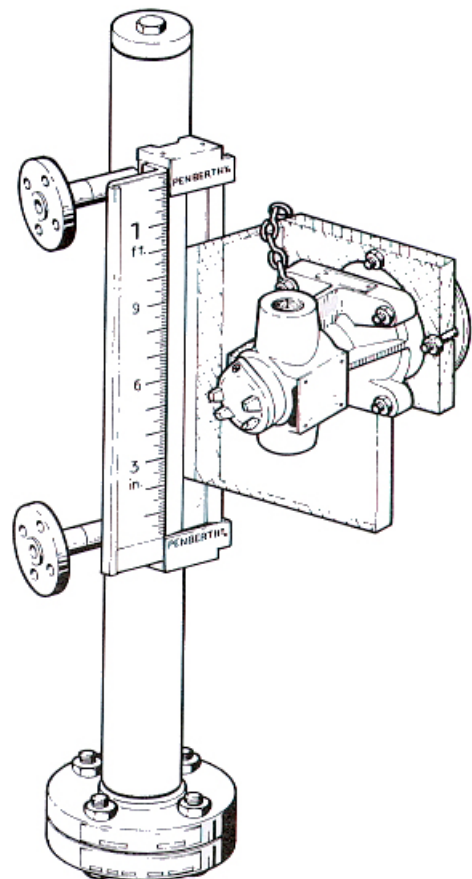
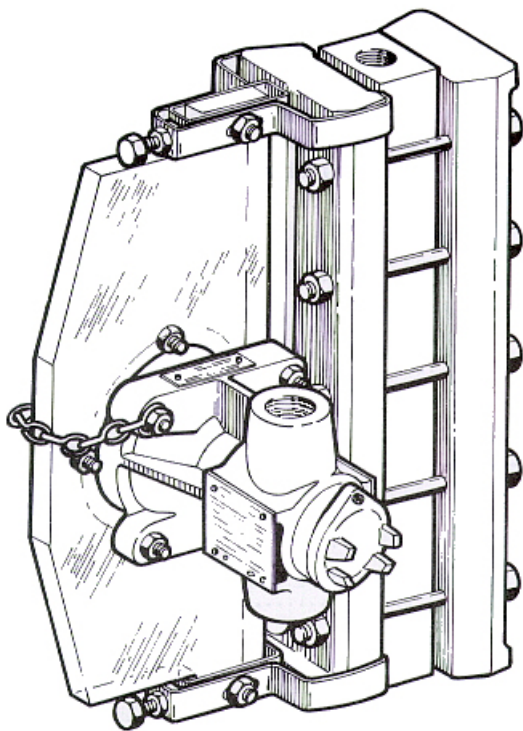

Installation, Operation and Maintenance Instructions

# TABLE OF CONTENTS

Product Warranty . . . . .	iii
1.0 About the Manual . . . . .	1
2.0 Introduction . . . . .	1
2.1 System Description . . . . .	2
3.0 Available Models . . . . .	2
3.1 Approvals . . . . .	3
3.2 AC Design Voltage Ratings . . . . .	4
3.3 Steam Application . . . . .	4
4.0 Inspection . . . . .	4
4.1 User Rating Inspection . . . . .	4,5
5.0 Installation . . . . .	5
5.1 Inspection and Cleaning of Glass . . . . .	5
5.2 Installation of Unit to Gage. . . . .	6,7
5.3 Electrical Installation . . . . .	7
6.0 Operation . . . . .	7
7.0 Maintenance . . . . .	7
7.1 Preventative Maintenance . . . . .	8
7.2 Accessing Maintenance Items . . . . .	8
7.3 Maintenance Procedures . . . . .	8
7.4 Troubleshooting . . . . .	8
8.0 Removal - Disassembly - Reassembly . . . . .	9
8.1 Disassembly . . . . .	9,10
8.2 Reassembly . . . . .	10,11
9.0 Disposal at End of Useful Life . . . . .	11
10.0 Telephone Assistance . . . . .	12
11.0 Exploded Parts Drawings . . . . .	13,14,15

**TABLES AND FIGURES** **page**

---

Table 1	Magnetic Gage Frost Proof Illuminator . . . . .	2
Table 2	Optional Model Structure . . . . .	3
Table 3	Design Voltage Ratings . . . . .	4
Table 4	Accessing Maintenance Items . . . . .	8
Figure 1	Side View of Illuminator Installation . . . . .	5
Figure 2	Top View of Illuminator Installation . . . . .	5
Figure 3	Nut Loosening Sequence . . . . .	9
Figure 4	Nut Tightening Sequence . . . . .	11
Figure 5	Exploded Parts Drawing of Flat Glass Illuminator . . . . .	13
Figure 6	Exploded Parts Drawing of Magnetic Gage Illuminator . . . . .	14
Figure 7	Installation of Illuminator to Reflex Gage . . . . .	15

## **PENBERTHY PRODUCT WARRANTY**

Tyco Valves & Controls Prophetstown warrants its Penberthy products as designed and manufactured by TV&C Prophetstown to be free of defects in the material and workmanship for a period of one year after the date of installation or eighteen months after the date of manufacture, whichever is earliest. TV&C Prophetstown will, at its option, replace or repair any products which fail during the warranty period due to defective material or workmanship.

Prior to submitting any claim for warranty service, the owner must submit proof of purchase to TV&C Prophetstown and obtain written authorization to return the product. Thereafter, the product shall be returned to TV&C in Prophetstown, Illinois, with freight paid.

This warranty shall not apply if the product has been disassembled, tampered with, repaired or otherwise altered outside of TV&C Prophetstown factory, or if it has been subject to misuse, neglect or accident.

The responsibility of TV&C Prophetstown hereunder is limited to repairing or replacing the product at its expense. TV&C Prophetstown shall not be liable for loss, damage or expenses related directly or indirectly to the installation or use of its products, or from any other cause or for consequential damages. It is expressly understood that TV&C Prophetstown is not responsible for damage or injury caused to other products, buildings, personnel or property, by reason of the installation or use of its products.

THIS IS TV&C PROPHETSTOWN'S SOLE WARRANTY AND IN LIEU OF ALL OTHER WARRANTIES, EXPRESSED OR IMPLIED WHICH ARE HEREBY EXCLUDED, INCLUDING IN PARTICULAR ALL WARRANTIES OF MERCHANTABILITY OR FITNESS FOR A PARTICULAR PURPOSE.

This document and the warranty contained herein may not be modified and no other warranty, expressed or implied, shall be made by or on behalf of TV&C Prophetstown unless made in writing and signed by the General Manager or Director of Engineering of TV&C Prophetstown.

# INSTALLATION, OPERATION and MAINTENANCE MANUAL FOR PENBERTHY GAGE ILLUMINATORS

## 1.0 About the Manual

This manual has been prepared as an aid and guide for personnel involved in installation or maintenance. All instructions must be read and understood thoroughly before attempting any installation, operation or maintenance.

# SAFETY INSTRUCTIONS

Penberthy does not have any control over the manner in which its illuminators are handled, installed or used. Penberthy cannot and will not guarantee that an illuminator is suitable or compatible for the user's specific application.



## WARNING

Vessel fluids may be pressurized in the gage on which the illuminator is being attached. Fluids can unexpectedly exit vessel connections due to apparatus or material failure. Safety glasses should be worn when installing an illuminator. Failure to follow *any* instruction could possibly result in a malfunction of the illuminator resulting in a loss of ability to read fluid level or failure of the liquid level gage resulting in leakage causing serious personal injury, electric shock or property damage.

## 2.0 Introduction

Penberthy illuminators are designed to be readily mounted and able to fit channeled indicator assemblies on Penberthy's Multiview™ magnetic liquid level meters and any style Penberthy flat glass liquid level gage.

Single and double section illuminators provide uniform light distribution over the entire length of the liquid level gage assemblies.

Single illuminators for Multiview™ magnetic gages are constructed in lengths up to four feet. Two illuminators can be butted against one another to cover up to eight feet in length continuously.

## 2.1 System Description

Penberthy illuminators are comprised of four basic components. Use the exploded parts view in Section 11.0 as additional reference material.

**Illuminator Body/Cover** – a rigid, aluminum, protective structure that supports and houses the illuminating elements of the illuminator. The reflector wedge is positioned between the cover and body by a bolting system such that the light dispersion is maximized.

**Illuminator Housing** – provides the electrical connection from the power source to the lamp. Located within the illuminator body, the housing holds the lamp in position.

**Reflector Wedge** – machined and polished PMMA light guide. Used to channel light from the lamp into a long plane (light bar).

**Brackets (flat glass gage only)** – uses a bolting system to mount illuminator to the flat glass gage cover. Bolts pass through the reflector wedge to affix the illuminator to the centerline of gage vision (transparent style gage only).

## 3.0 Available Models

Penberthy flat glass gage illuminators are available in single section units, double section units and in combinations of single and double section units for three or more section gages. Single and double section frost proof illuminators can be used in flat glass cryogenic applications.

Wedge depth is a critical factor when applying an illuminator in cryogenic applications. If the depth is too shallow, frost may build up on the end of the wedge making it difficult or impossible to read the fluid level.

MAGNETIC GAGE  
FROST PROOF ILLUMINATOR

Minimum Wedge Depth	Lowest Temperature
4" [100mm]	-94°F [ -70°C]
6" [150 mm]	-148°F [-100°C]
8" [200 mm]	-211°F [-135°C]
10" [250 mm]	-274°F [-170°C]
12" [300 mm]	-328°F [-200°C]

Table 1

## OPTIONAL STRUCTURE

The standard illuminator rating is 60 watts at 115 Vac. Other illuminators are listed in the options in Table 2 on the next page.

I	D	S	N	7	N	1	6
I = illuminator							2 = 25w – pigtail leads
S = single section flat glass							3 = 25w – terminal block
D = double section flat glass							6 = 60 w – pigtail leads
L = LED single sect flat glass							7 = 60 w – terminal block
M = magnetic gage (inch incr)							1 = 115 Vac standard thread 1" NPTF
N = LED mag gage (inch incr)							A = 115 Vac ISO thread M20 X 1.5
							2 = 230 Vac standard thread 1" NPTF
							B = 230 Vac ISO thread M20 X 1.5
							4 = 24 Vdc standard thread 1" NPTF
S = standard extension							D = 24 Vdc ISO thread M20 X 1.5
F = frost extension							
						N (not applicable - if flat glass); MAG GAGE INDICATOR LENGTH (unit digit of inches; e.g., 24 inches use "4", max. 48 inches)	
4, 6, 8, A(10), C(12), N (not applicable – standard extension) = WEDGE DEPTH (Mag Gage Only) (inch) refer to Table 1						GLASS SIZE (1, 2, 3..., 9); MAG GAGE INDICATOR LENGTH (tens digit of inches; e.g., 24 inches use "2", max. 48 inches)	

EXAMPLE: standard illuminator for double section size 7 flat glass gage (2TM7) with 60 watt bulb and 115 volt service.

### Optional Model Structure

Table 2

#### 3.1 Approvals

Units are explosion proof  
FM approved  
Division 1 and 2  
Class I: B, C, D  
Class II: E, F, G  
Class III, Type 4

CSA certified Ex d  
Division 1 and 2  
Class I: B, C, D  
Class II: E, F, G  
Class III, Type 4

CENELEC  
EExd IIB + H<sub>2</sub> T4 IP66

### 3.2 AC Design Voltage Ratings

Illuminator Nominal Rating	Applicable Voltage Range
115 Vac	108 Vac - 125 Vac
230 Vac	207 Vac - 250 Vac

**Table 3**

To determine the maximum allowable voltage within the design limits stated in the tables, the user should consult the lamp manufacturer or Penberthy, or when provided, the specifically stated design limits on a Penberthy product proposal.



**NEVER exceed these design ratings or application data. Exceeding design ratings or application data may result in creating excessive heat and potential ignition of volatile fluids that could cause death, serious personal injury and/or property damage.**

### 3.3 Steam Application

Penberthy light guides are constructed of PMMA which has a degradation temperature of 225°F (107°C). Should an illuminator be purchased for steam or other high temperature application gage usage, the steam or process temperature must be low enough and/or a cooling system must be used to maintain 225°F (107°C) or less at illuminator surfaces.

### 4.0 Inspection

**OPERATIONAL NOTE: Exercise care in handling illuminator parts to avoid scratching, denting, or otherwise damaging the polished edge of the reflector wedge. Any marks on the polished edge, as well as dirt, paint or tape will result in a reduction of light output.**

Upon receipt of an illuminator, check all components carefully for damage incurred in shipping. If damage is evident or suspected, do not attempt installation. Notify carrier immediately and request damage inspection. Refer to the exploded view drawing in Section 11.0 to inventory parts.

#### 4.1 User Rating Inspection

The user should confirm that:

1. The illuminator size, rating and model number stamped on nameplate (163) conforms to the description on the user's purchase order.
2. The operating conditions described in the purchase order agree with the actual operating conditions at the installation site.
3. The actual operating conditions at the installation site are within the application data shown on the Penberthy Technical Data Bulletin or product proposal referred to previously.
4. The materials of construction of the illuminator are compatible with the surrounding atmosphere in the specific application.

# SAFETY INSTRUCTIONS

If the size, model or performance data of the illuminator as received does not conform with any of the criteria above, do not proceed with installation. Contact an authorized Penberthy distributor for assistance. The incorrect illuminator voltage can result in unacceptable performance and potential damage to the illuminator.

## 5.0 Installation

Installation should only be undertaken by qualified personnel who are familiar with this equipment. They should have read and understood all of the instructions in this manual. The user should refer to Penberthy dimension sheets or Penberthy product proposal to obtain dimensional information for the specific size and model illuminator.

### ILLUMINATOR INSTALLATION

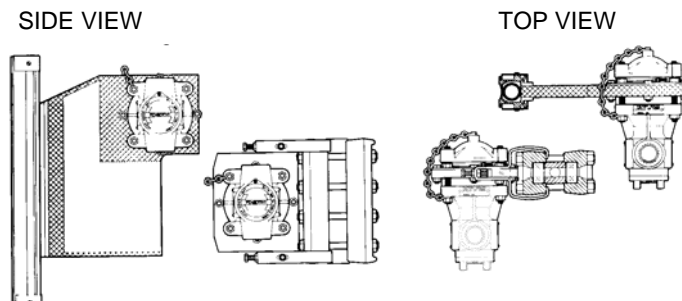

Figure 1

Figure 2

It is the user's responsibility to assure that knowledgeable installation personnel plan and carry out the installation in a safe manner. The following procedures are some of the guidelines that should be employed.

#### 5.1 Inspection and Cleaning of Glass

Penberthy recommends that prior to installation of an illuminator to a gage, that the gage glass be cleaned and inspected per instructions as follows:

1. Clean glass within vision slot using a non-abrasive household cleaner. DO NOT use wire brush, metal scraper or any device which could scratch the glass.
2. Inspect the surface of the glass for any signs of clouding, etching, scratching or physical damage such as bruises, checks or erosion that penetrates the outer surface of the glass. Shining a light at approximately a 45° angle will aid in detecting some of these conditions. Light will glisten more brightly on glass imperfections than the surrounding glass when reflecting light. Detection of any such problem areas or surface wear is sufficient evidence of damage. Do not proceed with installation with damaged glass. See appropriate Installation, Operation and Maintenance manual and replace glass.

## 5.2 Installation of Unit to Gage

Become familiar with the illuminator components before proceeding with installation. Refer to the exploded parts drawing in Section 11.0 when performing the following installation instructions:

### FLAT GLASS - Transparent

1. Mount illuminator to flat glass gage as shown in Figures 1 and 2.
2. Thread nut (4C) onto screw (100G).
3. Assemble Tinnerman nut (4D) to top of bracket (73).
4. Thread screw (100G) through nut (4D) on the mounting bracket (73) and thread nut (4E) onto end of screw (100G) until tight.
5. Repeat steps 2 through 4 for the other bracket (73).
6. Slip collar (139) over top end of the reflector (120) so that the indentation on the end of the collar is facing the top of the reflector (angled edge).
7. Place the upper mounting bracket (73) over the collar and insert screw (100F) through both the bracket and collar.
8. Install washer (125) over end of screw (100F) and thread on nut (4C) hand tight.
9. While holding the illuminator in place on the gage, slip the upper bracket over the top end of the gage cover and hand tighten screw (100G) to hold the illuminator in place.
10. Slip collar (139) over bottom end of the reflector (120) with the indentation facing the top of the illuminator (angled edge). Slip bracket (73) over the bottom end of the gage cover and collar, insert screw (100F) through both the bracket and collar. Install washer (125) over end of screw (100F) and thread on nut (4C) hand tight.
11. Adjust the reflector (120) so that it aligns with the vision slot of the gage and wrench tighten screws (100G) one turn beyond hand tight and secure screws by tightening nuts (4C).
12. Wrench tighten screws (100F).

### MAGNETIC GAGE

1. Place magnetic gage indicator on a flat surface with the flag or follower style indicator facing upward.
2. Remove end cap screws and end caps.
3. Slide top spacer (115A) over the flag or follower style indicator into the aluminum channel. Adjust the spacer such that it fits even with the top of the indicator channel and RTV into place.
4. Slide illuminator assembly over the flag or follower style indicator into the aluminum channel. Adjust the assembly such that it fits snugly against the top spacer (115A) and RTV into place.
5. Slide bottom spacer (115) over the flag or follower style indicator into the aluminum channel. Adjust the bottom spacer such that it fits snugly against the illuminator assembly and RTV into place.
6. Replace the end caps and screws.
7. When RTV is dry, secure the illuminator to the standpipe using the adjustable clamps provided. Hold the illuminator on the standpipe while hooking the clamp ends into the sides of the aluminum channel.
8. Turn the screw in the clamp until the illuminator is secured to the standpipe.
9. FOR WEDGES OVER 3 FEET: Using an ohmmeter, touch the painted portion of the illuminator wedge with one probe and a conductive point that is known to be grounded with the other probe. The resistance value must be less than one ohm.

### FLAT GLASS - Reflex

1. Mount illuminator to reflex style flat glass gage as shown in Figure 7.
2. Illuminators mounted to reflex style gages are single section only. Multiple section

- gages will require an illuminator for each glass section.
3. Remove the appropriate nuts from the gage bolts. The gage bracket (73) will be mounted onto two gage bolts and situated in the middle of the gage glass section.
  4. Install gage bracket (73) over gage bolts and secure to gage cover with gage nuts. Torque gage nuts to the proper torque as specified in the gage Installation, Operation and Maintenance Instructions provided with the gage.
  5. Attach illuminator bracket (73A) to gage bracket (73) using screws (100), lockwashers (126) and nuts (4) provided.
  6. Remove the nuts from the studs on the bottom side (polished reflector edge) of the illuminator.
  7. Slide the illuminator studs into the holes in the illuminator bracket (73A). Secure the illuminator to the bracket using lockwashers (126A) and nuts which were removed previously from the studs.

### 5.3 Electrical Installation



**DO NOT proceed with electrical installation unless the illuminator has been mounted to the gage according to instructions in Section 5.2 and is grounded. Only qualified electricians who have read and understood local and national electrical code should connect the illuminator to an electrical source. Failure to follow any of the above instructions can result in damage to the illuminator, gage, surrounding property or severe physical injury to personnel.**

The electrical installation should be performed by a qualified electrician and comply with applicable codes (U.S. - refer to National Electric Code NFPA current edition; Canada - refer to Canadian Electrical Code CSA C22) or other regulations as applicable. The conduit must be run in such a manner that it is not supported by or does not serve as a support for the illuminator.

### 6.0 Operation

Check that all installation procedures have been completed. Use only qualified experienced personnel who are familiar with illuminators and thoroughly understand the implications of the tables and all the instructions. Check that illuminator has sufficient light output over the entire visible length of the liquid level gage or magnetic gage.

### 7.0 Maintenance



**Use only qualified experienced personnel who are familiar with illuminators and thoroughly understand the implications of the tables and all the instructions. DO NOT proceed with any maintenance unless: 1) the gage assembly has been relieved of pressure or vacuum, has been allowed to reach ambient temperature and has been drained or purged of all fluids and 2) electrical power has been turned off. Failure to do so can cause death, serious personal injury or property damage.**

The user must create maintenance schedules, safety manuals and inspection details for each specific installation of an illuminator.

## 7.1 Preventative Maintenance

On all installations, the following items should be regularly evaluated by the user for purposes of maintenance:

1. *Reflector*, for signs of dirt build up, scratches or breakage
2. *Mounting Brackets* or cover flange nuts, for signs of loosening

The user must determine upon evaluation of his or her own operating experience an appropriate maintenance schedule necessary for his or her specific application. Realistic maintenance schedules can only be determined with full knowledge of the services and application situation involved.

## 7.2 Accessing Maintenance Items

Maintenance Item	Steps to follow to access Maintenance Item	
	Disassembly Section 8.1	Reassembly Section 8.2
glass lens cleaning	1 through 6	9 through 15
lamp replacement	1 through 5	10 through 15

**Table 4**

## 7.3 Maintenance Procedures

**Cleaning the Reflector** - Wash with a non-abrasive soap or detergent and water using a soft, grit-free cloth or sponge. When cleaning grease and oil from reflector, use only hexane, kerosene or aliphatic naphtha (no aromatic content) and a soft, grit-free cloth. **DO NOT** use solvents such as acetone, benzene, carbon tetrachloride, dry cleaning fluid or lacquer thinners since they will attack the surface of the reflector. After surface has been cleaned and rinsed of foreign particles, it may be dried with a clean, soft, damp chamois or grit-free cloth.

**IMPORTANT:** **DO NOT** use hard, rough cloths on edge of reflector because they will scratch the polished surface. The scratches will result in reduced light output of the illuminator.

**Cleaning the Lens** - Wash with a commercial glass cleaner. **DO NOT** use a wire brush, metal scraper or any device that might scratch the glass.

## 7.4 Troubleshooting

**INTERNAL OR EXTERNAL CORROSION** could be an indication of a harsh service environment. An investigation should immediately be carried out to determine the cause of the problem. It is the user's responsibility to choose a material of construction compatible with both the contained fluid and the surrounding atmosphere.

## 8.0 Removal - Disassembly – Reassembly



Use only qualified experienced personnel who are familiar with illuminators and thoroughly understand the implications of the tables and all the instructions. **DO NOT** proceed with any maintenance unless the gage assembly has been relieved of all pressure or vacuum, has been allowed to reach ambient temperature, has been drained or purged of all fluids and the electrical power has been turned off. Failure to do so can cause death, serious personal injury or property damage.

### 8.1 Disassembly

Refer to the exploded parts drawing in Section 11.0 for additional reference during disassembly and reassembly of the illuminator.

- 1) Disconnect electrical power source from illuminator.
- 2) Hold illuminator firmly. Loosen and remove screw (100C) and nut (4) closest to the boot clamp screw (100D). (See Figure 3)
- 3) Remove 4 flanged nuts (4B) in the sequence shown in Figure 3.
- 4) Remove lamp cover (1).
- 5) Remove lamp (113).
- 6) Remove lens (118).
- 7) Remove boot clamp (80).
- 8) Remove 4 jam nuts (4A) on lamp cover side of reflector (120).
- 9) Remove 3 remaining screws (100C) and nuts (4).
- 10) Remove boot (142) and boot backing plate (164) from reflector (120).
- 11) Pull studs (3) through the reflector (120) and remove body (11).

#### FLAT GLASS ILLUMINATOR – Transparent Only

- 12) Loosen nut (4C) and screw (100G) on bottom bracket (73) of reflector (120).
- 13) Loosen and remove nut (4C), washer (125) and screw (100F) from the bottom bracket (73) and remove the bottom bracket (73) and collar (139).
- 14) While holding reflector (120) to keep it from falling, loosen upper bracket (73) screws (100F, 100G) and remove reflector (120) along with the upper bracket assembly intact from the gage.

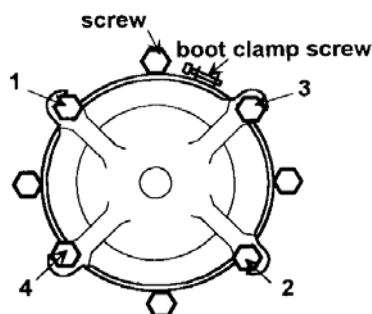

**Nut Loosening Sequence**  
**Figure 3**

## MAG GAGE ILLUMINATOR

- 12A) Scrape away RTV between the edge of the reflector (120) and the level indicator housing.
- 13A) Remove end cap screws and end cap from the end that is most convenient for vertical removal of reflector (120).
- 14A) Slide reflector (120) vertically along the level indicator housing channel and remove.

### 8.2 Reassembly

Refer to the exploded parts drawing in Section 11.0 for additional reference during disassembly and reassembly of the illuminator.

#### FLAT GLASS ILLUMINATOR – Transparent Only

- 1) Place upper bracket assembly with reflector (120) over top end of gage cover and snug down bracket (73) by tightening screws (100F, 100G) finger tight.
- 2) Place lower collar (139) on reflector (120) with the indentation facing the top of the reflector (angled edge). Slide bracket (73) in position over bottom end of gage cover and over collar (139) on reflector (120).
- 3) Secure bracket (73) to reflector (120) by placing screw (100F) through the bracket (73), collar (139) and reflector (120). Place washer (125) and nut (4C) on screw (100F) and tighten finger tight.
- 4) Adjust reflector (120) so that it aligns with the vision slot of the gage and wrench tighten end screws (100G) one turn beyond hand tight and secure end screws by tightening nuts (4C). Wrench tighten screws (100F).

## MAG GAGE ILLUMINATOR

- 1A) Remove any debris or RTV residue from the indicator channel and (insertion end) end cap area.
- 2A) Carefully slide reflector (120) vertically into the indicator housing channel. (Reflector may need to be held in position while assembling a lower end cap).
- 3A) Place a 1/8" (3 mm) bead of RTV on both sides of the reflector between the outer edge of the reflector and the indicator housing. Smooth the RTV bead by pressing a damp lint free cloth along the length of each RTV bead.
- 4A) Place a 1/8" (3 mm) bead of RTV along the end of the indicator housing channel, replace end cap and secure with end cap screws.

NOTE: Check that O-ring (39A) is properly seated in its groove in body (11).

- 5) Slide body studs (3) through the reflector (120) and replace boot (142) and boot backing plate (164) over body studs (3) and around the lip of the body (11).
- 6) Replace 3 screws (100C) and nuts (4).
- 7) Replace 4 jam nuts (4A) on body studs (3). Ensure that jam nuts (4A) create a level seating surface for the lamp cover (1) and do not interfere or touch the boot (142).



**Care should be taken when positioning jam nuts at an appropriate stud height. If uneven or excessive stress is applied to the glass lens, the lens may break and cause personal injury or property damage.**

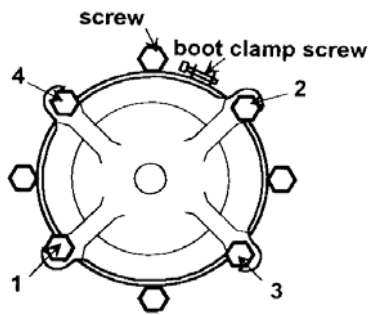

**Nut Tightening Sequence  
Figure 4**

- 8) Carefully replace the boot clamp (80) around the boot (142) so that the boot clamp screw (100D) is located in the area where the screw (100C) is not yet assembled.
- 9) Replace lens (118).
- 10) Replace lamp (113).
- 11) Replace lamp cover (1). Use small flat blade or pick to assist in fitting the lip of lamp cover (1) into boot (142).
- 12) Replace 4 flanged nuts (4B) and tighten in a sequence as shown in Figure 4, until they bear on the lamp cover (1). Then turn the flanged nuts (4B) an additional  $\frac{1}{4}$  to  $\frac{1}{2}$  turn.  
**NOTE:** When tightening flanged nuts, pressure should be applied to the center of the domed portion of the lamp cover to insure contact between the cover and the lens.
- 13) Snug boot clamp screw (100D). Monitor the clamp as the screw is tightened to insure that the clamp does not creep away from the boot.
- 14) Replace screw (100C) and nut (4) closest to the boot clamp screw (100D).
- 15) Ensure that electrical components are properly grounded and restore electrical power.

Refer to Section 6.0 for operation of the illuminator when returned to service.

### 9.0 Disposal at End of Useful Life

Penberthy Gage Illuminators are used in a variety of fluid applications. By following the appropriate federal and industry regulations, the user must determine the extent of preparation and treatment the Gage Illuminator must incur before its disposal. A Material Safety Data Sheet (MSDS) may be required before disposal services accept certain components.

Metal, glass and polymers should be recycled whenever possible. Refer to order and TV&C - Prophetstown Material Specification sheets for materials of construction.

## 10.0 Telephone Assistance

If you are having difficulty with your Gage Illuminator, contact your local Penberthy distributor. You may also contact the factory direct at (815) 537-2311 and ask for an applications engineer. So that we may assist you more effectively, please have as much of the following information available as possible when you call:

- Model #
- Name of the company from whom you purchased the Gage Illuminator
- Invoice # and date
- Process conditions (pressure, flow rates, tank shape, etc)
- A brief description of the problem
- Trouble shooting procedures that failed

If attempts to solve your problem fail, you may request to return your Gage Illuminator to the factory for intensive testing. You must obtain a Return Authorization (R.A.) number from TV&C Prophetstown before returning anything. Failure to do so will result in the unit being returned to you without being tested, freight collect. To obtain an R.A. number, the following information (in addition to that above) is needed:

- Reason for return
- Person to contact at your company
- "Ship To" address

There is a minimum charge for evaluation of non-warranty units. You will be contacted before any repairs are initiated should the cost exceed the minimum charge. If you return a unit under warranty, but it is not defective, the minimum charge will apply.

## 11.0 Exploded Parts Drawings

### RECOMMENDED SPARE PARTS

Ref. No.	Item	Qty.
113	Lamp	1
118	Lens	1
142	Boot	1
164	Plate	1
120	Reflector	1
1	Cover	1

### FLAT GLASS ILLUMINATOR

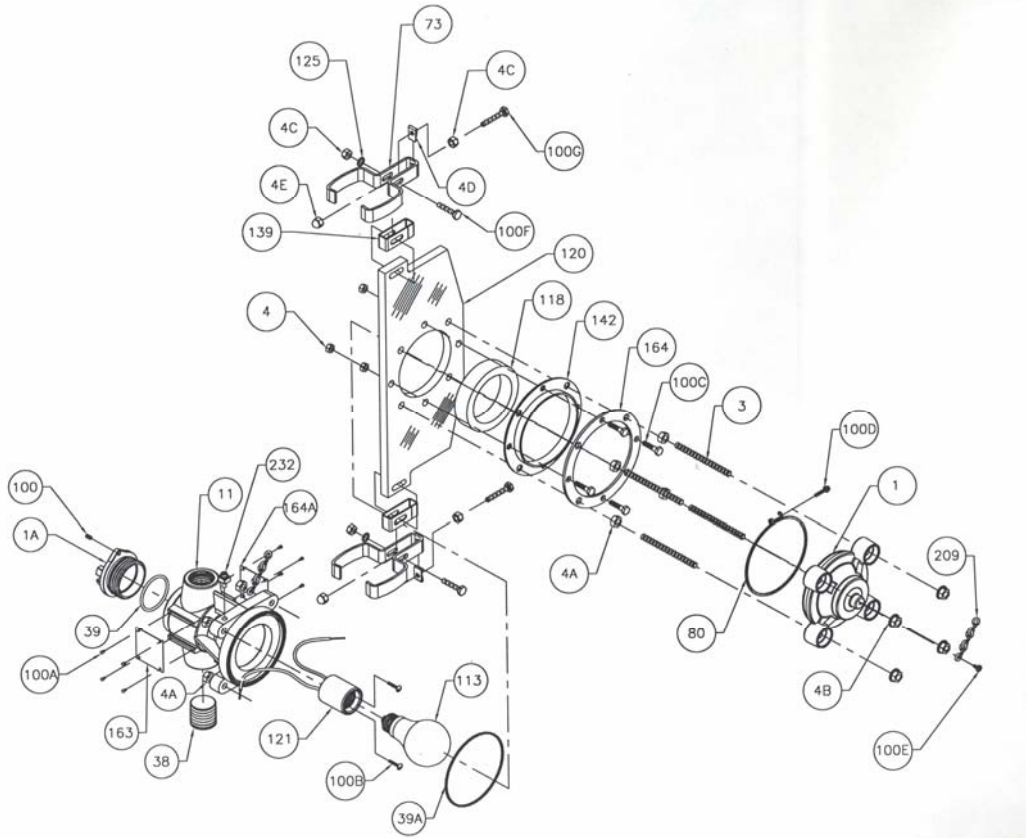

Figure 5

1	Cover	100C	Screw
1A	Cover, Back	100D	Screw
3	Stud	100E	Screw
4	Nut	100F	Screw
4A	Nut	100G	Screw
4B	Nut, Flange	113	Lamp
4C	Nut	118	Lens
4D	Nut, Tinnerman	120	Reflector
4E	Nut, Acorn	121	Socket, Lamp
11	Body	125	Washer
38	Plug	139	Collar
39	O-ring	142	Boot
39A	O-ring	163	Nameplate
73	Bracket	164	Plate, Backing
80	Clamp	164A	Plate, Caution
100	Screw, Set	209	Chain
100A	Screw, Drive	232	Terminal, Earth Ground
100B	Screw		

**RECOMMENDED SPARE PARTS**

Ref. No.	Item	Qty.
113	Lamp	1
118	Lens	1
142	Boot	1
164	Plate	1
120	Reflector	1
1	Cover	1

**MAGNETIC GAGE ILLIMINATOR**

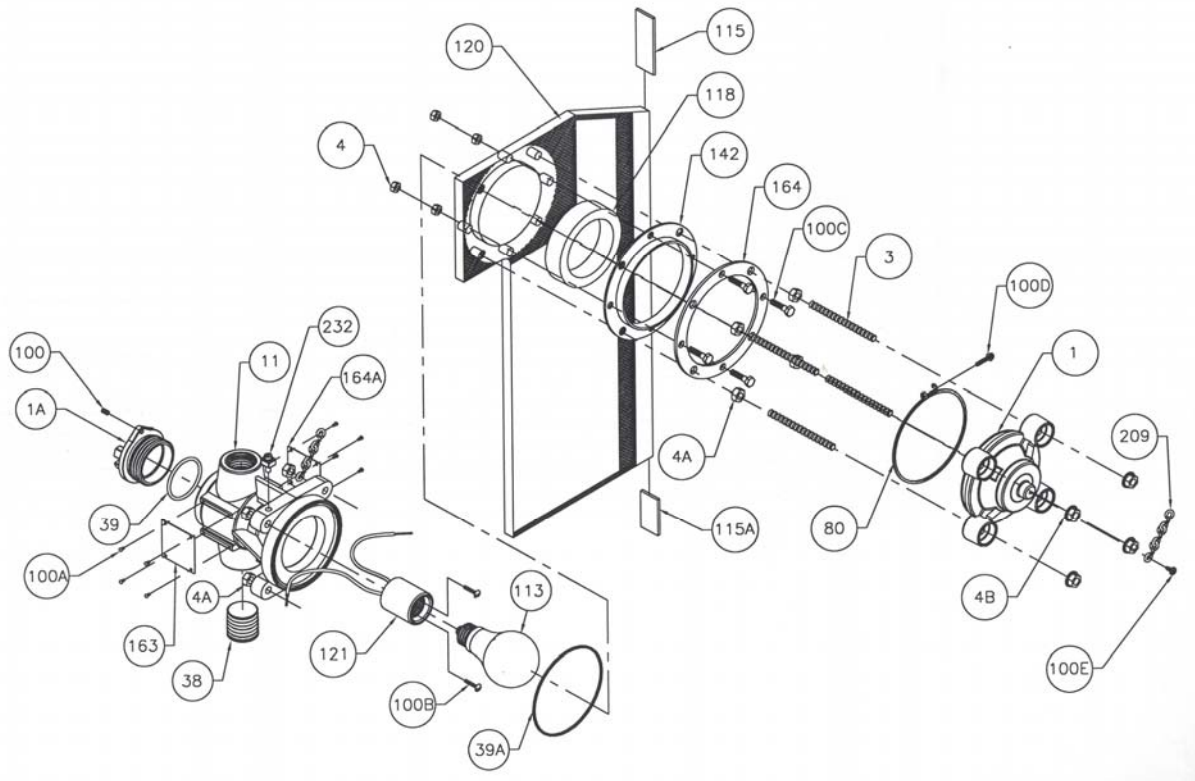

**Figure 6**

- |      |              |      |                        |
|------|--------------|------|------------------------|
| 1    | Cover        | 100D | Screw                  |
| 1A   | Cover, Back  | 100E | Screw                  |
| 3    | Stud         | 113  | Lamp                   |
| 4    | Nut          | 115  | Spacer                 |
| 4A   | Nut          | 115A | Spacer, Top            |
| 4B   | Nut, Flange  | 118  | Lens                   |
| 11   | Body         | 120  | Reflector              |
| 38   | Plug         | 121  | Socket, Lamp           |
| 39   | O-ring       | 142  | Boot                   |
| 39A  | O-ring       | 163  | Nameplate              |
| 80   | Clamp        | 164  | Plate, Backing         |
| 100  | Screw, Set   | 164A | Plate, Caution         |
| 100A | Screw, Drive | 209  | Chain                  |
| 100B | Screw        | 232  | Terminal, Earth Ground |
| 100C | Screw        |      |                        |

# INSTALLATION TO REFLEX GAGE

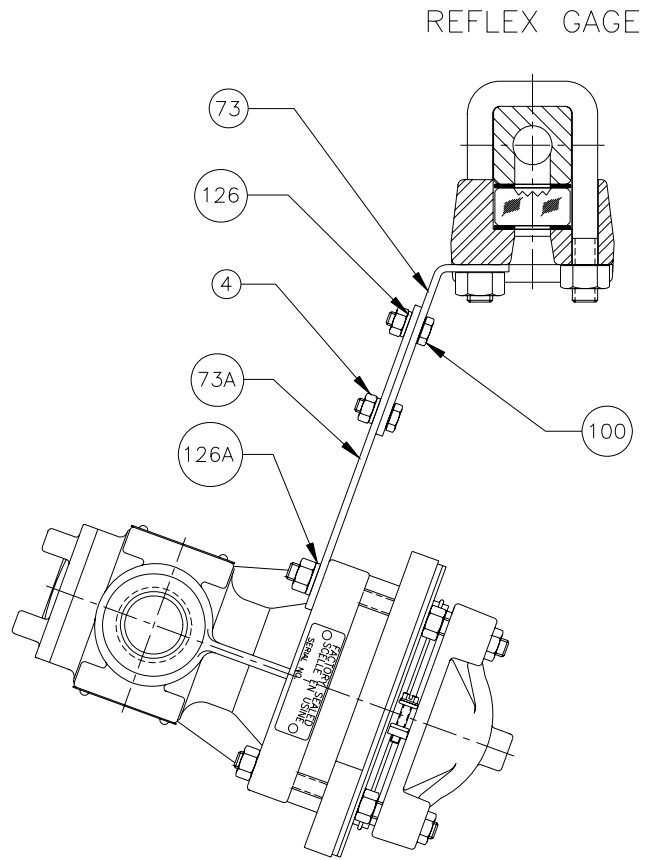

**Figure 7**

- 4 Nut
- 73 Bracket, Gage
- 73A Bracket, Illuminator
- 100 Screw
- 126 Lockwasher
- 126A Lockwasher

# PENBERTHY

## DECLARATION of CONFORMITY

In conformance with ISO/IEC Guide 22 - 96  
LGI.DC r C

Manufacturer's Name: Tyco Valves & Controls  
Manufacturer's Address: 320 Locust Street  
Prophetstown, IL 61277-1147 U.S.A.

Product:

Type of Equipment: Illuminators for level gauges  
Equipment Class: Industrial Lighting – Hazardous Area  
Model Designations: lxxxxxx : where x's are voltage, wattage and mechanical dimensioning

The product described above is in conformity with:

92/59/EEC	General Product Safety	1992
89/392/EEC	Machinery	1989
73/23/EEC	Low Voltage	1973
89/336/EEC	Electromagnetic compatibility	1989
EN 50081-1	Generic emission	1992
EN 50081-2	Generic emission	1994
EN 50082-1	Generic immunity	1992
EN-50082-2	Generic immunity	1995
EN-55011	Industrial, scientific and medical	1991
CISPR 11	Specification for limits and methods of measurement	1990
ISO 7-1	Pipe threads where pressure-tight joints are made	1994
BS 21	Pipe threads for tubes and fittings where pressure-tight	1985
BS 970 Part 1	Wrought steels for mechanical and allied engineering	1996
BS 970 Part 3	Wrought steel for mechanical and allied engineering	1991
BS 1501 Part 3	Steels for pressure purposes	1990
BS 1640 Part 1	Steel butt-welding pipe fittings	1962
BS 1640 Part 2	Steel butt-welding pipe fittings	1962
BS 3602 Part 1	Steel pipes and tubes for pressure purposes	1987
BS 3643	ISO metric screw threads	1981
BS 3799	Steel pipe fittings, screwed and socket-welding	1974
CSA C22.2 #30	Explosion-proof enclosures for use in class I hazardous	1986
NFPA-NEA	Article 500	1996
ANSI/ASME B1.1	Unified screw inch threads un and unr thread form	1982
ANSI/ASME B1.20.1	Pipe threads, general purpose (inch)	1983
ANSI/ASME B18.3	Socket cap shoulder and set screws inch series	1982
ANSI/ASME B18.6.3	Machine screws and machine screw nuts	1972

Date: 01 December 2004

Signature:



Prophetstown, IL U.S.A.

Name:

David J. Williams, C.Q.E.

Position:

Quality Assurance Manager

Technical Construction File is available at stated address. Signatory is contact person.

**tyco** / *Flow Control* / **Tyco Valves  
& Controls**

**Penberthy**

Tyco Valves & Controls, L.P. Prophetstown  
320 Locust St., Prophetstown, Illinois 61277  
Phone: 815-537-2311  
FAX: 815-537-5764  
Printed in USA  
Part No. 18BH3-009

© 2008 Tyco Valves & Controls, L.P. Prophetstown, All Rights Reserved