

PENBERTHY®

# Flat Glass Gage Scales

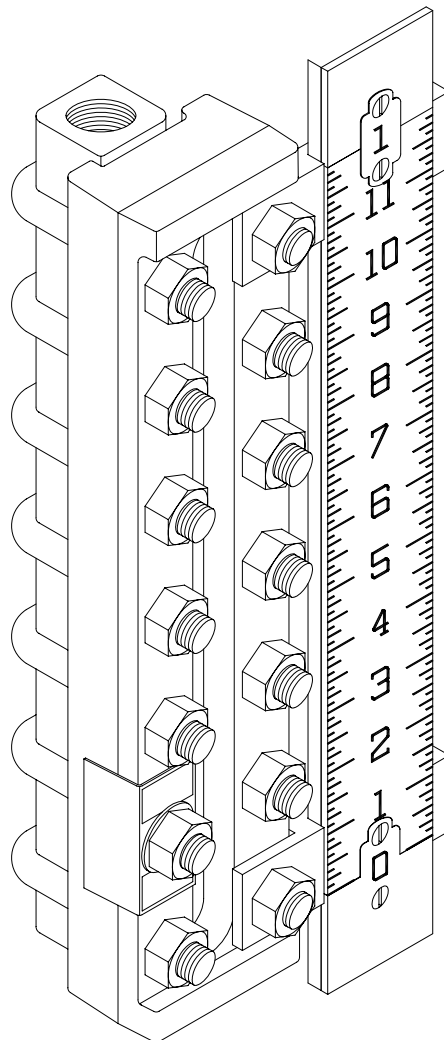

Installation, Operation and Maintenance Instructions

# TABLE OF CONTENTS

Product Warranty	. . . . .	iii
1.0 About the Manual	. . . . .	1
2.0 Introduction	. . . . .	1
2.1 Standard Scale Description	. . . . .	1,2
2.2 Special Scale Description	. . . . .	2
3.0 Inspection	. . . . .	2
3.1 User Inspection	. . . . .	2
4.0 Installation	. . . . .	2
4.1 Preparation.	. . . . .	3
4.2 Mounting to Un-mounted Liquid Level Gage	. . . . .	3
4.3 Mounting to Mounted Liquid Level Gage	. . . . .	3,4
5.0 Operation	. . . . .	4
5.1 Pre-Operational Check	. . . . .	4
5.2 Operating	. . . . .	4
6.0 Maintenance	. . . . .	5
6.1 Preventative Maintenance	. . . . .	5
6.2 Maintenance Procedure	. . . . .	5
7.0 Removal – Disassembly – Reassembly	. . . . .	5
7.1 Disassembly	. . . . .	6
7.2 Reassembly	. . . . .	6
8.0 Disposal at End of Useful Life	. . . . .	7
9.0 Telephone Assistance	. . . . .	7
10.0 Exploded Parts Drawing	. . . . .	8
<b>Tables and Figures</b>		<b>page</b>
Figure 1	Exploded Parts Drawing . . . . .	8

## PENBERTHY PRODUCT WARRANTY

Tyco Valves & Controls Prophetstown warrants its Penberthy products as designed and manufactured by TV&C Prophetstown to be free of defects in the material and workmanship for a period of one year after the date of installation or eighteen months after the date of manufacture, whichever is earliest. TV&C Prophetstown will, at its option, replace or repair any products which fail during the warranty period due to defective material or workmanship.

Prior to submitting any claim for warranty service, the owner must submit proof of purchase to TV&C Prophetstown and obtain written authorization to return the product. Thereafter, the product shall be returned to TV&C in Prophetstown, Illinois, with freight paid.

This warranty shall not apply if the product has been disassembled, tampered with, repaired or otherwise altered outside of TV&C Prophetstown factory, or if it has been subject to misuse, neglect or accident.

The responsibility of TV&C Prophetstown hereunder is limited to repairing or replacing the product at its expense. TV&C Prophetstown shall not be liable for loss, damage or expenses related directly or indirectly to the installation or use of its products, or from any other cause or for consequential damages. It is expressly understood that TV&C Prophetstown is not responsible for damage or injury caused to other products, buildings, personnel or property, by reason of the installation or use of its products.

**THIS IS TV&C PROPHETSTOWN'S SOLE WARRANTY AND IN LIEU OF ALL OTHER WARRANTIES, EXPRESSED OR IMPLIED WHICH ARE HEREBY EXCLUDED, INCLUDING IN PARTICULAR ALL WARRANTIES OF MERCHANTABILITY OR FITNESS FOR A PARTICULAR PURPOSE.**

This document and the warranty contained herein may not be modified and no other warranty, expressed or implied, shall be made by or on behalf of TV&C Prophetstown unless made in writing and signed by the General Manager or Director of Engineering of TV&C Prophetstown.

# INSTALLATION, OPERATION and MAINTENANCE MANUAL FOR PENBERTHY FLAT GLASS GAGE SCALES

## 1.0 About the Manual

This manual has been prepared as an aide and guide for personnel involved in installation or maintenance. All instructions must be read and understood thoroughly before attempting any installation, operation or maintenance.

# SAFETY INSTRUCTIONS

Penberthy does not have any control over the manner in which its gage scales are handled, installed or used. Penberthy cannot and will not guarantee that a gage scale is suitable or compatible for the user's specific application.



## WARNING

Vessel fluids may be pressurized and can unexpectedly exit vessel connections due to apparatus or material failure. Safety glasses should be worn when installing a gage scale. Failure to follow *any* instruction could possibly result in an inability to accurately measure the contained fluid or a malfunction of the liquid level gage with resulting sudden release of pressure, severe physical injury or property damage.

## 2.0 Introduction

Penberthy flat glass gage scales are used to measure the level of the contained fluid in the pressure vessel or holding tank. Penberthy standard flat glass gage scales are made of a strong weather resistant metal that has a black finish with graduation marks that are raised 1/32 in. [0.8 mm] and contrast with the finish of the scale for ease in reading. Penberthy standard flat glass gage scales are furnished in one foot increments from one foot to twelve feet in length and are assembled complete.

### 2.1 Standard Scale Description

Penberthy standard flat glass gage scales are comprised of seven basic components. Use the exploded parts view in Section 11.0 as additional reference material.

Strip - a one foot long metal strip with inch markings and 1/8 in. graduations. The strips are stacked when length of measurement is greater than one foot.

Bottom Plate – attached to the bottom of the strip to indicate the zero line of indication.

Top Plate – attached to the top of the strip to hold the insert that indicates the actual foot length of indication.

Insert – a metal piece with the foot increment engraved in it. Used to attach the foot long strips together and the top plate to the top strip.

Backing Plate – an aluminum strip onto which the strip, bottom plate, top plate and insert are attached to give the scale some rigidity.

Screws – countersunk head machine type used to attach the strip, bottom plate, top plate and insert to the backing plate.

Mounting Bracket – used to hold the gage scale in position on the flat glass gage. The mounting bracket is attached to the gage bolting by use of the existing nut and bolt and the gage scale is held in position in the bracket with a set screw provided with the bracket.

## 2.2 Special Scale Description

Penberthy special flat glass gage scales are provided completely assembled. All parts of the gage scale are mounted onto the backing plate during factory assembly. The mounting brackets are the only components which are not assembled to the gage scale.

## 3.0 Inspection

Upon receipt of a flat glass gage scale, check all components carefully for damage incurred in shipping. If damage is evident or suspected, do not attempt any installation. Notify carrier immediately and request damage inspection. Refer to exploded view drawing in Section 11.0 to inventory parts.

### 3.1 User Inspection

The user should confirm that:

1. The gage scale quantity and length conforms to the description on the user's purchase order
2. The length described in the purchase order agrees with the actual required length at the installation site

# SAFETY INSTRUCTIONS

**If the length or quantity of the gage scale as received does not conform with any of the criteria above, do not proceed with installation. Contact an authorized Penberthy distributor for assistance.**

## 4.0 Installation

Installation should only be undertaken by qualified personnel who are familiar with this equipment. They should have read and understood all of the instructions in this manual. The user should refer to Penberthy product proposal to obtain dimensional information.



## WARNING

**Use only qualified experienced personnel who are familiar with liquid level gage equipment. DO NOT proceed with any installation of gage scales to the liquid level gage unless the liquid level gage has been relieved of all pressure or vacuum, has been allowed to reach ambient temperature and has been drained or purged of all fluids. Failure to follow instructions can cause serious personal injury and property damage.**

#### 4.1 Preparation

1. Secure a work bench with sufficient width and length to accommodate the gage scale. If the gage scale is to be mounted onto a liquid level gage which has not been mounted into service, the bench should be of sufficient size to accommodate the liquid level gage also.
2. Penberthy gage scale mounting brackets are furnished with a hex wrench for use with the set screw in the mounting brackets. Locate the wrench prior to beginning installation.

#### 4.2 Mounting to Un-mounted Liquid Level Gage

1. Loosen and remove the top and bottom nuts from the bolts on one side of the liquid level gage and any additional nuts depending on the number of brackets being used.  
**Note:** Penberthy standard gage scales are provided with two mounting brackets. If the installation is subject to vibration or wind factors, it is recommended placing mounting brackets at intervals of two feet to four feet.
2. Place brackets on bolts with the bracket inset away from the liquid level gage, thread nuts on finger tight.
3. Loosen the set screw in the mounting brackets.
4. Place the gage scale into the insets of the mounting brackets. The "0" reading of the gage scale should be aligned with the bottom of the vision slot in the liquid level gage.  
**Note:** If the gage scale is longer than desired, the top end of the scale may be cut off to the desired length. The scale should be marked and cut prior to securing in the mounting brackets. After cutting to desired length, using a #29 drill, drill a hole through strip and backing plate at the top of the scale. Tap the hole with a #8-32 tap. Remove the screw from the top plate and use it to secure the strip to the backing plate.
5. Hold the scale firmly in place in the bracket insets; tighten the set screws of the mounting brackets using the hex wrench provided.
6. Using a torque wrench, tighten all gage nuts to the proper torque value as specified in the liquid level gage Installation, Operation and Maintenance Instructions provided.



## WARNING

Failure to comply with the proper torquing sequence or force value can lead to leakage, gasket blow-out or glass breakage resulting in gage failure, serious personal injury or property damage.

#### 4.3 Mounting to Mounted Liquid Level Gage



## WARNING

Use only qualified experienced personnel who are familiar with liquid level gage equipment. DO NOT proceed with gage scale installation unless the liquid level gage has been relieved of all pressure or vacuum, has been allowed to reach ambient temperature and has been drained or purged of all fluids. Failure to follow instructions can cause serious personal injury and property damage.

1. Loosen and remove the top and bottom nuts from the bolts on one side of the liquid level gage and any additional nuts depending on the number of brackets being used.  
**Note:** Penberthy standard gage scales are provided with two mounting brackets. If the installation is subject to vibration or wind factors, it is recommended placing mounting brackets at intervals of two feet to four feet.
2. Place brackets on bolts with the bracket inset away from the liquid level gage, thread nuts on finger tight.
3. Loosen the set screw in the mounting brackets.
4. Place the gage scale into the insets of the mounting brackets. The "0" reading of the gage scale should be aligned with the bottom of the vision slot in the liquid level gage.  
**Note:** If the gage scale is longer than desired, the top end of the scale may be cut off to the desired length. The scale should be marked and cut prior to securing in the mounting brackets. After cutting to desired length, using a #29 drill, drill a hole through strip and backing plate at the top of the scale. Tap the hole with a #8-32 tap. Remove the screw from the top plate and use it to secure the strip to the backing plate.
5. Hold the scale firmly in place in the bracket insets; tighten the set screws of the mounting brackets using the hex wrench provided.
6. Using a torque wrench, tighten all gage nuts to the proper torque value as specified in the liquid level gage Installation, Operation and Maintenance Instructions provided.



## WARNING

**Failure to comply with the proper torquing sequence or force value can lead to leakage, gasket blow-out or glass breakage resulting in gage failure, serious personal injury or property damage.**

### 5.0 Operation

#### 5.1 Pre-Operational Check

1. Assure that all installation procedures have been completed.
2. Assure that the gage scale is secure and well supported.
3. Assure that the gage scale is located correctly.

#### 5.2 Operating

Flat glass gages should be brought into service slowly. The glass used in Penberthy flat glass gages is tempered and can withstand minimal thermal shock and mechanical stress.



## WARNING

**Gage and gagecock installations should be brought into service slowly. The glass used in flat glass gages is tempered and can withstand minimal thermal shock and mechanical stress. Gagecocks should be opened slightly, and the gage and gagecock assembly temperature and pressure allowed to slowly equalize. If the gagecocks are equipped with ball checks, the gagecocks must be opened all the way after the pressure and temperature have equalized to permit operation of the automatic ball check in the event of gage glass failure. Failure to follow the recommended operating procedures can result in severe personal injury or property damage.**

## 6.0 Maintenance

Maintenance should only be undertaken by qualified experienced personnel who are familiar with this equipment and have read and understood all the instructions in this manual.



**DO NOT** proceed with any maintenance unless the gage and gagecock assembly has been relieved of all pressure or vacuum, has been allowed to reach ambient temperature and has been drained or purged of all fluids. Failure to do so can cause serious personal injury and property damage.

### 6.1 Preventative Maintenance

On all installations the following items should be regularly evaluated by the user for purposes of maintenance:

1. Gage scales for cleanliness
2. Gage scales to insure that scales are secure and well supported
3. Gage scales for corrosion

The user must determine, upon evaluation of his or her own operating experience, an appropriate maintenance schedule necessary for his or her own specific application. Realistic maintenance schedules can only be determined with full knowledge of the services and application situation involved.

### 6.2 Maintenance Procedures

Clean gage scales with a non-abrasive soap or detergent and a soft grit-free clothe or sponge. After surface has been cleaned and rinsed of all foreign particles, it may be dried using a clean, soft, grit-free clothe.

## 7.0 Removal - Disassembly - Reassembly



**DO NOT** proceed with the removal of the gage scale unless the gage and gagecock assembly has been relieved of all pressure or vacuum, has been allowed to reach ambient temperature and has been drained or purged of all fluids. Failure to do so can cause serious personal injury and property damage.

## 7.1 Disassembly

Refer to the exploded parts drawing in Section 10.0 for additional reference during disassembly and reassembly of the gage scales.

- 1) While holding the gage scale firmly, loosen the set screw (100A) in the mounting brackets (73) with the hex wrench.
- 2) Remove the gage scale from the brackets (73) insets and place on work bench.
- 3) Remove screws (100), inserts (69), bottom plate (164), top plate (164A) and strip (122) from the backing plate (164B).

**Caution:** If gage scale mounting brackets (73) are to be removed from the flat glass gage, the gage must first be relieved of all pressure or vacuum, been allowed to reach ambient temperature and drained or purged of all fluids.

## 7.2 Reassembly

Refer to the exploded parts drawing in Section 10.0 for additional reference during disassembly and reassembly of the gagecocks.

- 1) Place backing plate (164B) on work bench.
- 2) Place bottom plate (164) and strip (122) on backing plate (164B). The bottom of the bottom plate (164) should be flush with the bottom of backing plate (164B).
- 3) If the gage scale has multiple strips, stack the strips (122) on top of one another along the length of the backing plate (164B).
- 4) Place top plate (164A) on the top end of strip (122).
- 5) Place insert(s) (69) on top of the strip (122) to strip (122) joint, if required, and the strip (122) to top plate (164A) joint. Make sure when placing insert(s) (69) on the strip(s) that the numbering sequence is correct (ex.: 1, 2, 3, etc. from the bottom of the scale to the top).
- 6) Attach the insert(s) 69, strip(s) 122, bottom plate (164) and top plate (164A) to the backing plate (164B) with screws (100).
- 7) If mounting brackets (73) were removed during disassembly, place brackets on the bolts with the bracket inset away from the flat glass gage, thread nuts on finger tight.
- 8) Place the gage scale into the insets of the mounting brackets (73). The "0" reading of the gage scale should be aligned with the bottom of the vision slot in the flat glass gage.
- 9) Hold the scale firmly in place in the bracket (73) insets, tighten the set screws (100A) using the hex wrench.
- 10) If mounting brackets (73) were removed during disassembly, using a torque wrench, tighten all gage nuts to the proper torque value as specified in the flat glass gage Installation, Operation and Maintenance Instructions provided.



## WARNING

**Failure to comply with the proper torquing sequence or force value can lead to leakage, gasket blow-out or glass breakage resulting in gage failure, serious personal injury or property damage.**

**Note:** Refer to Section 5.0 Operation when returning to service.

## **8.0 Disposal at End of Useful Life**

Penberthy flat glass gage scales are used in a variety of fluid applications. By following the appropriate federal and industry regulations, the user must determine the extent of preparation and treatment the flat glass gage scale must incur before its disposal. A Material Safety Data Sheet (MSDS) may be required before disposal services accept certain components.

Metal, glass and polymers should be recycled whenever possible. Refer to order and TV&C - Prophetstown Material Specification sheets for materials of construction.

## **9.0 Telephone Assistance**

If you are having difficulty with your flat glass gage scale, contact your local Penberthy distributor. You may also contact the factory direct at (815) 537-2311 and ask for an applications engineer. So that we may assist you more effectively, please have as much of the following information available as possible when you call:

- Model #
- Name of the company from whom you purchased the Penberthy Series N2 or K2 gagecocks
- Invoice # and date
- A brief description of the problem
- Trouble shooting procedures that failed

If attempts to solve your problem fail, you may request to return your Penberthy flat glass gage scale to the factory for intensive inspection. You must obtain a Return Authorization (R.A.) number from TV&C Prophetstown before returning anything. Failure to do so will result in the item being returned to you without being inspected, freight collect. To obtain an R.A. number, the following information (in addition to that above) is needed:

- Reason for return
- Person to contact at your company
- "Ship To" address

There is a minimum charge for evaluation of non-warranty items. You will be contacted before any repairs are initiated should the cost exceed the minimum charge. If you return an item under warranty, but is not defective, the minimum charge will apply.

## 10.0 Exploded Parts Drawing

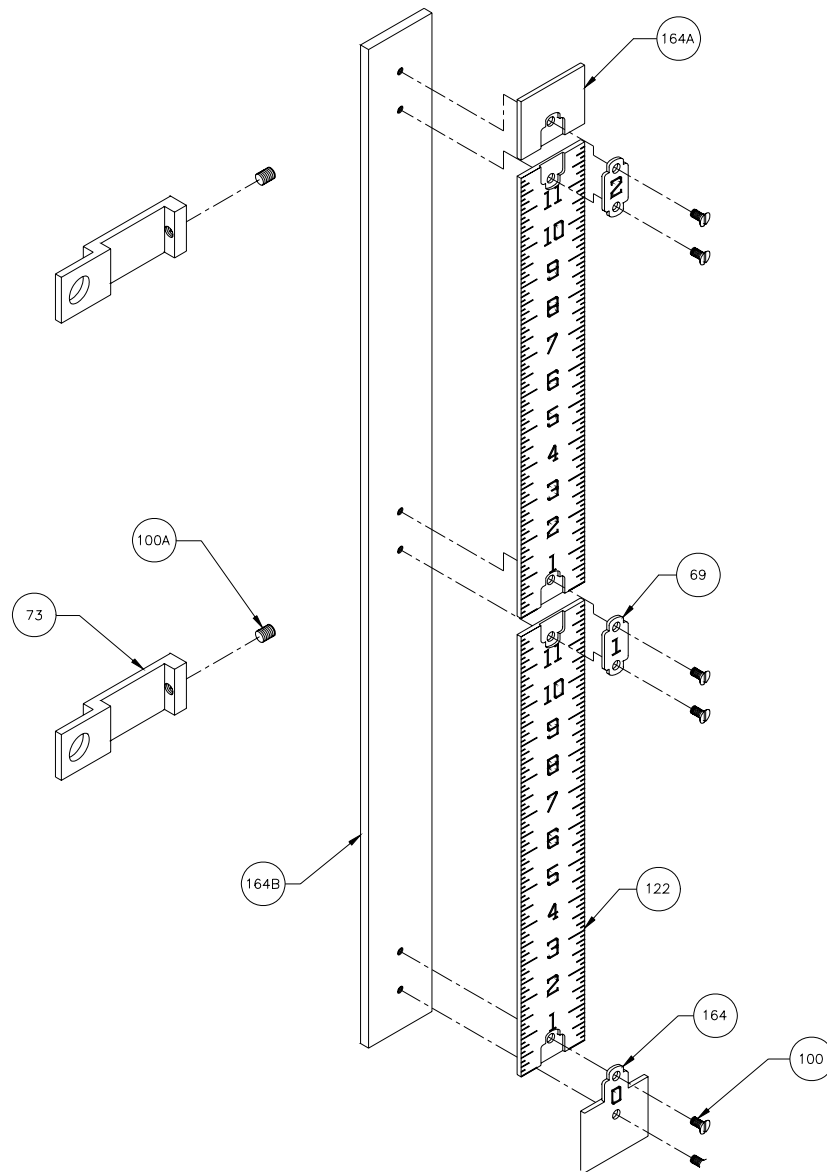

**Figure 1**

- 73 Bracket
- 164 Plate, Bottom
- 164A Plate, Top
- 164B Plate, Backing
- 69 Insert
- 100 Screw
- 100A Screw, set
- 122 Strip

**tyco** / *Flow Control* / **Tyco Valves  
& Controls**

**Penberthy**

Tyco Valves & Controls, L.P. Prophetstown  
320 Locust St., Prophetstown, Illinois 61277  
Phone: 815-537-2311  
FAX: 815-537-5764  
Printed in USA  
Part No. 16494-009

© 2008 Tyco Valves & Controls, L.P. Prophetstown, All Rights Reserved