

PENBERTHY®

Refractive Protector / Glass Union

For use with Tubular Glass Gages

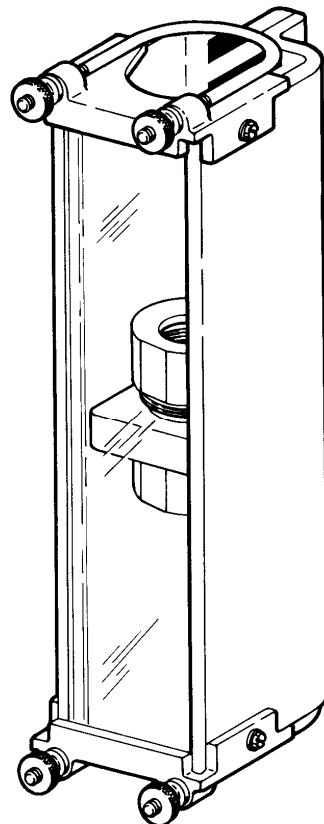

Installation, Operation and Maintenance Instructions

TABLE OF CONTENTS

Product Warranty	iii
1.0 About the Manual	1
2.0 Introduction - Refractive Protector.	1
2.1 System Description	1
3.0 Available Models	1
4.0 Inspection	1,2
5.0 Installation	2
6.0 Operation	2
6.1 Pre-Operational Check	2
6.2 Operation	3
7.0 Maintenance	3
7.1 Preventative Maintenance	3
7.2 Maintenance Procedures	3
7.3 Disassembly - Reassembly	3
8.0 Introduction - Glass Union	4
9.0 Available Models	4
9.1 Pressure/Temperature Ratings for a Single Piece of Tubular Glass	4
9.2 Pressure/Temperature Ratings for Various Glass Packing.	5
10.0 Inspection	5
11.0 Installation	6
12.0 Operation	6
13.0 Maintenance	6
13.1 Preventative Maintenance	7
13.2 Disassembly - Reassembly	7
14.0 Disposal at End of Useful Life	7
15.0 Telephone Assistance	7
16.0 Exploded Parts Drawing - Refractive Protector & Glass Union	8
 <u>TABLES AND FIGURES</u>	
Table 1	4
Table 2	5
Figure 1	8

PENBERTHY PRODUCT WARRANTY

Tyco Valves & Controls, LP warrants its Penberthy products as designed and manufactured by TV&C, LP to be free of defects in the material and workmanship for a period of one year after the date of installation or eighteen months after the date of manufacture, whichever is earliest. TV&C, LP will, at its option, replace or repair any products which fail during the warranty period due to defective material or workmanship.

Prior to submitting any claim for warranty service, the owner must submit proof of purchase to TV&C, LP and obtain written authorization to return the product. Thereafter, the product shall be returned to TV&C, LP in Harlingen, Texas, with freight paid.

This warranty shall not apply if the product has been disassembled, tampered with, repaired or otherwise altered outside of TV&C, LP factory, or if it has been subject to misuse, neglect or accident.

The responsibility of TV&C, LP hereunder is limited to repairing or replacing the product at its expense. TV&C, LP shall not be liable for loss, damage or expenses related directly or indirectly to the installation or use of its products, or from any other cause or for consequential damages. It is expressly understood that TV&C, LP is not responsible for damage or injury caused to other products, buildings, personnel or property, by reason of the installation or use of its products.

THIS IS TV&C, LP'S SOLE WARRANTY AND IN LIEU OF ALL OTHER WARRANTIES, EXPRESSED OR IMPLIED WHICH ARE HEREBY EXCLUDED, INCLUDING IN PARTICULAR ALL WARRANTIES OF MERCHANTABILITY OR FITNESS FOR A PARTICULAR PURPOSE.

This document and the warranty contained herein may not be modified and no other warranty, expressed or implied, shall be made by or on behalf of TV&C, LP unless made in writing and signed by the General Manager or Director of Engineering of TV&C, LP.

INSTALLATION, OPERATION and MAINTENANCE MANUAL FOR PENBERTHY REFRACTIVE PROTECTOR / GLASS UNION

1.0 About the Manual

This manual has been prepared as an aid and guide for personnel involved in installation or maintenance. All instructions must be read and understood thoroughly before attempting any installation, operation, or maintenance.

IMPORTANT Penberthy does not have any control over the manner in which it's Refractive Protector or Glass Union are handled, installed, or used. Penberthy cannot and will not guarantee that the Refractive Protector or Glass Union is suitable or compatible for the user's specific application.



Failure to follow *any* instruction could possibly result in a failure of the Refractive Protector or Glass Union to operate as designed causing physical injury or property damage.

2.0 Introduction – Refractive Protector

Penberthy's Refractive Protector is designed to mount easily to tubular glass gage assemblies. It protects the gage glass against damage from outside sources and minimizes injury or damage to property should the tubular glass be broken.

2.1 System Description

The Penberthy Refractive Protector is two pieces of extruded aluminum bolted together to form a channel. The interior has a white finish with 45° angle red stripes painted on the back wall. As the tubular glass gage fills, liquid passes in front of the stripes. The refractive nature of this liquid fill changes the stripe angle thereby indicating the level of the vessel.

If water is the liquid used, the stripes become horizontal. Liquids with a refractive index less than water will alter the angle less. Liquids with a refractive index greater than water will alter the angle more.

The Refractive Protector should only be used in conjunction with High Pressure glass. Use with other types of tubular glass will interfere with the enhanced level indication characteristics.

3.0 Available Models

Penberthy Refractive protectors are available with either a clear polymeric or glass cover. The length of the protector is based upon the center to center dimensions of the vessel connections.

4.0 Inspection

Upon receipt of your Refractive Protector, check all components carefully for damage incurred in shipping. If damage is evident or suspected, do not attempt installation. Notify carrier immediately and request damage inspection.

A typical Penberthy Refractive Protector consists of (2) aluminum extrusions which form the body, (1) cover, (2) U-bolts, (4) nuts, (2) brackets, and bolts and nuts for connecting the extrusions. The quantity of bolts and nuts will be determined by the length of the protector.

Glass packing protector nuts are also required when the Refractive Protector is used in conjunction with any standard gagecock except K3 gagecocks. They are not needed when utilizing hydraulic adapters. The glass packing protector nuts are **not** included with the protector.

The user should confirm that:

- A. The length of the protector and cover material delivered matches the size and model described on the purchase order.
- B. The operating conditions originally described match the actual conditions at the installation site.
- C. The materials of construction for the Refractive Protector delivered are compatible with the conditions at the installation site.

SAFETY INSTRUCTIONS

If the size, model, or performance data of the Refractive Protector as received does not conform to any of the criteria above, do not proceed with installation. Contact an authorized Penberthy distributor for assistance. The incorrect protector may result in unacceptable performance and potential damage to the tubular glass.

5.0 Installation

Installation should only be undertaken by qualified personnel who are familiar with this equipment. They should have read and understood all of the instructions in this manual. Check the exploded view to verify the proper orientation of the protector and its parts.

Prior to installing the Refractive Protector, insure that, if necessary, the glass packing protector nuts have replaced the standard glass packing nuts.

- 1. Hold one of the aluminum extrusions up to the gagecock assembly so the front of the protector is facing away from the vessel.
- 2. Insert the glass or plastic cover into the slot. (If a glass Union is being used, mark the union position and drill the necessary holes prior to completing the protector installation).
- 3. Hold the second aluminum extrusion up to the gagecock so the cover fits into its slot.
- 4. Check to see the holes in the back angle of each half line up. Insert the corresponding bolts. Thread and tighten the nuts.
- 5. Place the top and bottom bracket on the protector.
- 6. Install the U-bolts around the protector nuts and through the holes in the bracket. Thread and tighten the nuts finger tight.

6.0 Operation

6.1 Pre-Operational Check

Before start-up, the operator should assure that:

- a. All installation procedures have been completed.
- b. The Refractive Protector provides the proper protection over the entire length of the tubular glass in the gage assembly.

6.2 Operation

Follow the operating procedures outlined in your gagecock Installation/Operation/Maintenance manual. It is very important that the gage be brought into service slowly to avoid excessive shock on the tubular glass and potential glass breakage.



Failure to follow the recommended operating procedures for Tubular Glass Gages can result in the rapid pressurization of the gage assembly. This can cause glass breakage and a sudden loss of pressure resulting in serious personal injury and property damage.

7.0 Maintenance



Maintenance should only be undertaken by qualified experienced personnel who are familiar with this equipment and have read and understood all the instructions in this manual. Do not proceed with any maintenance on a Refractive Protector with the Tubular Glass Gage still at operating pressure or temperature. Relieve the unit of pressure or vacuum, allow it to reach ambient temperature and purge or drain it of all fluids. Failure to do so may result in personal injury or property damage.

7.1 Preventative Maintenance

The user must create maintenance schedules, safety manuals, and inspection details for each specific gage and gagecock installation. These will be based upon the users own operating experience with their specific application. Realistic maintenance schedules can only be determined with full knowledge of the services and application situation involved.

7.2 Maintenance Procedures

Clean glass/polymeric cover with a commercial glass cleaner and a soft, grit free cloth. DO NOT use a wire brush, metal scraper, or any other device which might scratch the glass/polymer.

7.3 Disassembly - Reassembly

To disassemble the unit, reverse the procedure detailed previously in Section 5.0.

When preparing to reassemble the unit, repeat the steps in Section 5.0.

8.0 Introduction – Glass Union

Penberthy's Glass Union is designed to join two pieces of tubular glass. This allows you to increase the length of your gage, yet maintain the pressure/temperature rating of the individual pieces of glass.

Glass Unions should be used in conjunction with the Refractive Protector to provide mechanical stability.



Glass Unions must be mechanically secured to a base for proper operation. The external support can be in the form of a Refractive Protector or some other type of bracket. Lack of longitudinal stabilization can result in the sight glass escaping from the Glass Union and the sudden loss of pressure and fluid resulting in serious personal injury and property damage.

9.0 Available Models

Glass Unions can be used with either 5/8" (16 mm) or 3/4" (19 mm) tubular glass. They are available in your choice of steel, brass, or stainless steel construction.

9.1 Pressure/Temperature Ratings for a Single Piece of Tubular Glass

Both 5/8" (16 mm) and 3/4" (19 mm) OD						
Center to Center Distance for Vessel Connections	No Corrosion Up To 150°F [66°C]			Stem Boiler Service Up To 425°F [218°C]		
	High Pressure	Heavy Wall	Red Line	High Pressure	Heavy Wall	Red Line
Inches [mm]	psig [kPaG]	psig [kPaG]	psig [kPaG]	psig [kPaG]	psig [kPaG]	psig [kPaG]
10 [254]	410 [2830]	600 [4140]	340 [2340]	310 [2140]	345 [2380]	275 [1900]
15 [381]	385 [2650]	600 [4140]	310 [2140]	280 [1930]	325 [2240]	265 [1830]
20 [508]	355 [2450]	600 [4140]	285 [1970]	265 [1830]	315 [2170]	260 [1790]
25 [635]	300 [2070]	580 [4000]	260 [1790]	250 [1720]	300 [2070]	250 [1720]
30 [762]	275 [1900]	550 [3790]	230 [1590]	Not Recommended		
35 [889]	240 [1650]	500 [3450]	200 [1380]			
40 [1016]	210 [1450]	420 [2900]	180 [1240]			
45 [1143]	200 [1380]	360 [2480]	170 [1170]			
50 [1270]	180 [1240]	340 [2340]	160 [1100]			
55 [1397]	150 [1030]	N/A	140 [970]			
60 [1524]	140 [970]	N/A	120 [830]			
65 [1651]	125 [860]	N/A	100 [690]			
70 [1778]	100 [690]	N/A	90 [620]			

Table 1

Using secured Glass Unions and multiple pieces of tubular glass will increase the pressure/temperature rating over that of an equivalent length of single glass.

9.2 Pressure and Temperature Ratings for Various Glass Packing

PRESSURE/TEMPERATURE DESIGN RATINGS			
Body Material	Glass Packing	5/8" (16 mm) OD	3/4" (19 mm) OD
Carbon Steel ASTM A105	Grafoil®	500 psig [3450 kPaG] at -20°F [-29°C] to +500°F [260°C]	500 psig [3450 kPaG] at -20°F [-29°C] to +500°F [260°C]
	Teflon®	500 psig [3450 kPaG] at -20°F [-29°C] to +500°F [260°C]	500 psig [3450 kPaG] at -20°F [-29°C] to +500°F [260°C]
	Neoprene® (Standard)	500 psig [3450 kPaG] at -20°F [-29°C] to +300°F [149°C]	500 psig [3450 kPaG] at -20°F [-29°C] to +300°F [149°C]
	Viton®	500 psig [3450 kPaG] at -20°F [-29°C] to +400°F [204°C]	500 psig [3450 kPaG] at -20°F [-29°C] to +400°F [204°C]
Bronze ASTM B150 C64200	Grafoil®	200 psig [1380 kPaG] at -325°F [-198°C] to +100°F [38°C] 125 psig [860 kPaG] at +400°F [204°C]	400 psig [2760 kPaG] at -325°F [-198°C] to +100°F [38°C] 250 psig [1720 kPaG] at +400°F [204°C]
	Teflon®	200 psig [1380 kPaG] at -325°F [-198°C] to +100°F [38°C] 125 psig [860 kPaG] at +400°F [204°C]	400 psig [2760 kPaG] at -325°F [-198°C] to +100°F [38°C] 250 psig [1720 kPaG] at +400°F [204°C]
	Neoprene® (Standard)	200 psig [1380 kPaG] at -65°F [-54°C] to +100°F [38°C] 165 psig [1140 kPaG] at +300°F [149°C]	400 psig [2760 kPaG] at -65°F [-54°C] to +100°F [38°C] 335 psig [2310 kPaG] at +300°F [149°C]
	Viton®	200 psig [1380 kPaG] at -20°F [-29°C] to +100°F [38°C] 125 psig [860 kPaG] at +400°F [204°C]	400 psig [2760 kPaG] at -20°F [-29°C] to +100°F [38°C] 250 psig [1720 kPaG] at +400°F [204°C]
316/316L STS ASTM A276	Grafoil®	500 psig [3450 kPaG] at -325°F [-198°C] to +500°F [260°C]	500 psig [3450 kPaG] at -325°F [-198°C] to +500°F [260°C]
	Teflon®	500 psig [3450 kPaG] at -325°F [-198°C] to +500°F [260°C]	500 psig [3450 kPaG] at -325°F [-198°C] to +500°F [260°C]
	Neoprene® (Standard)	500 psig [3450 kPaG] at -65°F [-54°C] to +300°F [149°C]	500 psig [3450 kPaG] at -65°F [-54°C] to +300°F [149°C]
	Viton®	500 psig [3450 kPaG] at -20°F [-29°C] to +400°F [204°C]	500 psig [3450 kPaG] at -20°F [-29°C] to +400°F [204°C]

Table 2

10.0 Inspection

Upon receipt of the Glass Union, check all components carefully for damage incurred in shipping. If damage is evident or suspected, do not attempt installation. Notify carrier immediately and request damage inspection.

A Penberthy Glass Union consists of the union itself and (2) #8 – 32 screws used to secure the union.

Prior to installation the user should confirm that:

- A. The material of construction and glass tube OD for which the unit is designed matches the size and model described on the purchase order.
- B. The operating conditions originally described match the actual conditions at the installation site.
- C. The materials of construction for the Glass Union delivered are compatible with the conditions at the installation site.

SAFETY INSTRUCTIONS

If the size, model, or performance data of the Glass Union as received does not conform to any of the criteria above, do not proceed with installation. Contact an authorized Penberthy distributor for assistance. The incorrect union can result in unacceptable performance and potential damage to the tubular glass gage.

11.0 Installation

Installation should only be undertaken by qualified personnel who are familiar with this equipment. They should have read and understood all of the instructions in this manual. Check the exploded view to ensure the Glass Union is not inverted.

1. Loosen and remove the glass packing nut, glass packing gland, and glass packing from both ends of the union.
2. Mount them on the sight glass prior to inserting the glass into the union. See Figure 1 for the proper sequence. **The glass packing should be flush with the end of the sight glass when finished.**
3. Insert the upper sight glass into the union until you have achieved a positive stop. Tighten the packing nut.
4. Insert the lower sight glass into the union until you have achieved a positive stop. Tighten the packing nut.
5. Follow the instructions in your gage gagecock IOM for installing the sight glass in the gagecocks.
6. Mark the position of the collar located in the center of the union body on the Refractor Protector or bracket you intend to secure to the union to.
7. Use the template supplied to locate and drill the two 3/16" (5 mm) holes required. If a Refractive Protector is being used, the holes should be drilled in the back of the protector.
8. Once the Refractive Protector or bracket is installed, secure the Glass Union using the pre-tapped holes and #8 – 32 screws provided.

12.0 Operation

After ensuring that all installation procedures have been completed, follow the operating procedures outlined in your gagecock Installation/Operation/Maintenance manual. It is very important that the gage be brought into service slowly to avoid excessive shock on the tubular glass and potential glass breakage.



Failure to follow the recommended operating procedures for Tubular Glass Gages can result in the rapid pressurization of the gage assembly. This can cause glass breakage and a sudden loss of pressure resulting in serious personal injury and property damage.

13.0 Maintenance

Maintenance should only be undertaken by qualified experienced personnel who are familiar with this equipment and have read and understood all the instructions in this manual.



Do not proceed with any maintenance on a Glass Union with the Tubular Glass Gage still at operating pressure or temperature. Relieve the unit of pressure or vacuum, allow it to reach ambient temperature and purge or drain it of all fluids. Failure to do so could result in personal injury or property damage.

13.1 Preventative Maintenance

The user must create maintenance schedules, safety manuals, and inspection details for each specific gage gagecock installation. These will be based upon the users own operating experience with their specific application. Realistic maintenance schedules can only be determined with full knowledge of the services and application situation involved.

13.2 Disassembly - Reassembly

To disassemble the unit, reverse the procedure detailed in Section 11.0.

When preparing to reassemble the union, replace the glass packing nut, glass packing gland, and glass packing on both the upper and lower connections.

Repeat the steps in Section 11.0.

14.0 Disposal at End of Useful Life

Penberthy Refractive Protector/Glass Unions are used in a variety of fluid applications. By following the appropriate federal and industry regulations, the user must determine the extent of preparation and treatment the Refractive Protector/Glass Union must incur before its disposal. A Material Safety Data Sheet (MSDS) may be required before disposal services accept certain components.

Metal, glass and polymers should be recycled whenever possible. Refer to order and TV&C, LP Material Specification sheets for materials of construction.

15.0 Telephone Assistance

If you are having difficulty with your Refractive Protector/Glass Union, contact your local Penberthy distributor. You may also contact the factory direct at (309) 946-5205 and ask for an applications specialist. So that we may assist you more effectively, please have as much of the following information available as possible when you call:

- Model #
- Name of the company from whom you purchased the Refractive Protector/Glass Union
- Invoice # and date
- Process conditions (pressure, flow rates, tank shape, etc)
- A brief description of the problem
- Trouble shooting procedures that failed

If attempts to solve your problem fail, you may request to return your Refractive Protector/Glass Union to the factory for intensive testing. You must obtain a Return Authorization (R.A.) number from TV&C, LP before returning anything. Failure to do so will result in the unit being returned to you without being tested, freight collect. To obtain a R.A. number, the following information (in addition to that above) is needed:

- Reason for return
- Person to contact at your company
- "Ship To" address

There is a minimum charge for evaluation of non-warranty units. You will be contacted before any repairs are initiated should the cost exceed the minimum charge. If you return a unit that is covered under warranty, but is not defective, the minimum charge will apply.

Grafoil[®] is a registered trademark of Graftech, Inc.
Neoprene[®], Viton[®], and Teflon[®] are registered trademarks of E.I. du Pont de Nemours and Company

16.0 Exploded Parts Drawing – Refractive Protector and Glass Union

Recommended Spare Parts		
REF #	ITEM	QTY
34	Packing, Glass	2
35	Retainer, Glass Packing	2
37	Nut, Glass Packing	1

GLASS UNION

- 11 Body
- 34 Packing, Glass
- 35 Retainer, Glass Packing
- 36 Gland, Glass Packing
- 37 Nut, Glass Packing

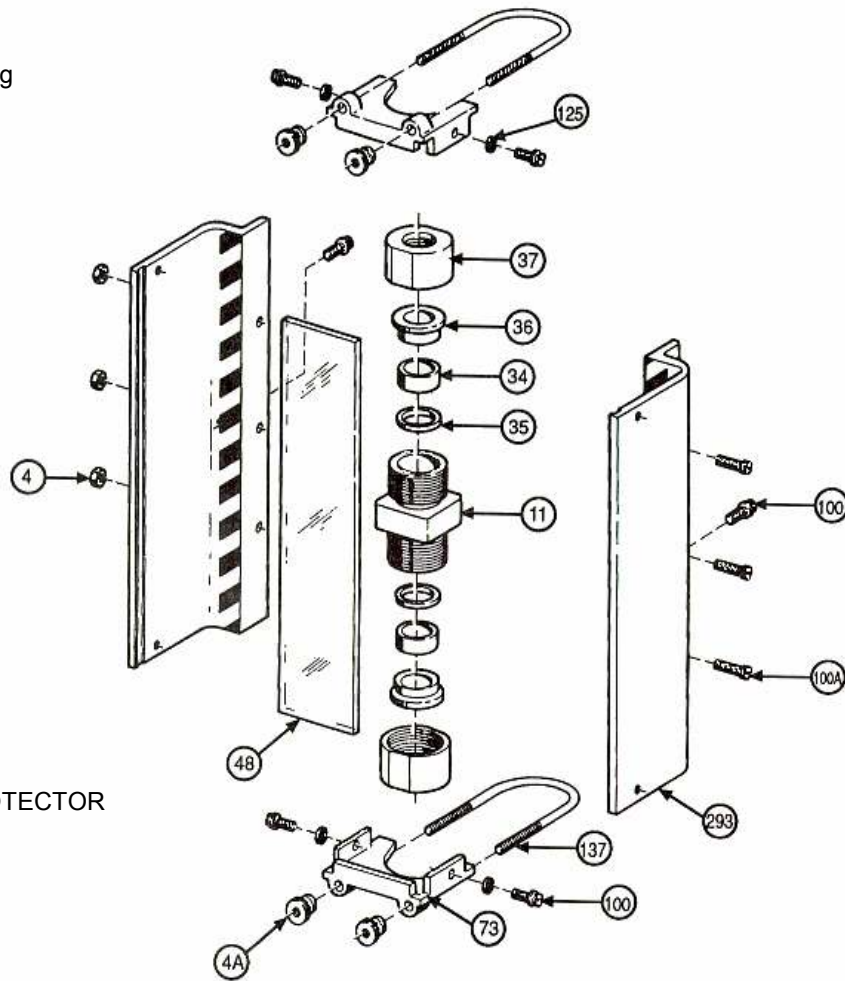

REFRACTIVE GLASS PROTECTOR

- 4 Nut
- 4A Nut
- 48 Glass or Polymer
- 73 Bracket
- 100 Screw
- 100A Screw
- 125 Washer (lock)
- 137 Bolt
- 293 Extrusion

Figure 1



Tyco Valves & Controls, LP
5801 East Harrison, Harlingen, Texas 78550
Phone: 309-946-5205
FAX: 309-946-5206
Printed in USA
Part No. 18K88-009

© 2012 Tyco Valves & Controls, LP, All Rights Reserved