

dimensions

For: MODELS SLL, SLM, SLH, SGL, SGH, SHLM

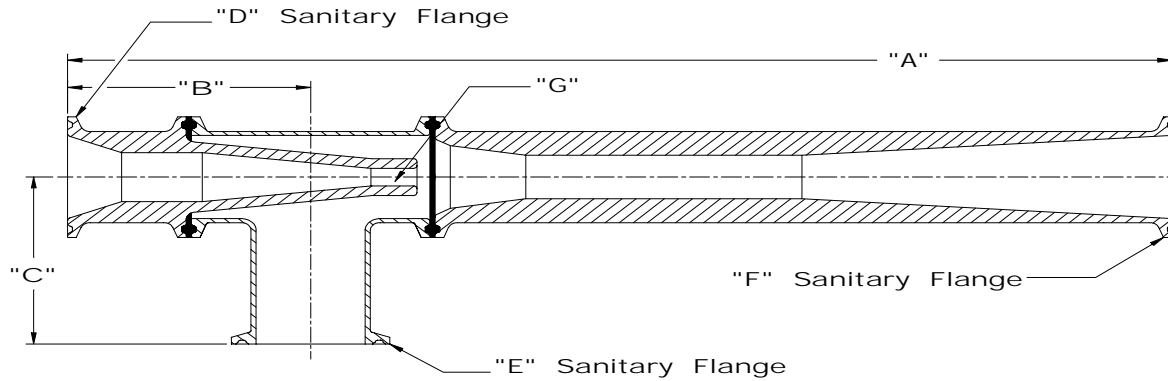

Unit Size	Model	Dimensions in Inches & [mm]					
		"A"	"B"	"C"	"D"	"E"	"F"
1	SLL, SLM, SLH	8-3/4	4-1/32	2-3/8	1 1/2	1 1/2	1 1/2
	SGL, SGH, SHLM	[222.3]	[102.4]	[60.3]			
1 1/2	SLL, SLM, SLH	13-7/8	3-15/16	2-3/4	1 1/2	1 1/2	1 1/2
	SGL, SGH, SHLM	[352.4]	[100.0]	[69.9]			
2	SLL, SLM, SLH	15-9/16	4-13/16	3-1/2	2	2	2
	SGL, SGH, SHLM	[395.3]	[122.3]	[88.9]			
3	SLL, SLM, SLH	24-3/4	5-9/16	3-3/4	3	3	3
	SGL, SGH, SHLM	[628.7]	[141.3]	[95.3]			

Maximum Particle Clearance				
Model	Dimension "G" in Inches & [mm]			
	Size			
	1	1-1/2	2	3
SLL	0.076 (1.930)	0.130 (3.302)	0.175 (4.445)	0.315 (8.001)
SLM	0.095 (2.413)	0.162 (4.115)	0.218 (5.537)	0.394 (10.008)
SLH	0.126 (3.200)	0.216 (5.486)	0.291 (7.391)	0.525 (13.335)
SGL	0.070 (1.778)	0.120 (3.048)	0.162 (4.115)	0.292 (7.417)
SGH	0.105 (2.667)	0.180 (4.572)	0.242 (6.147)	0.437 (11.100)
SHLM	0.095 (2.413)	0.162 (4.115)	0.218 (5.537)	0.394 (10.008)

