



## JET PUMP TECHNICAL DATA

# pumping gases

This technical bulletin includes general information about Penberthy Jet Pumps plus specific details for selecting the proper unit. The Penberthy Jet Pumps covered in this bulletin are used for pumping gases. The basic functions of all models included are either exhausting, evacuating or priming.

# introduction and applications

## How jet pumps operate

All jet pumps operate on the principle of a fluid entraining a second fluid. Although design and construction may vary, this applies to all jet pumps.

All jet pumps have three common features: inlet, suction, and discharge. Here is how these function:

**Inlet** – The operating medium (liquid, gas, or steam) under pressure enters the inlet and travels through the nozzle into the suction chamber. The nozzle converts the pressure of the operating medium into a high velocity stream, which passes from the discharge side of the inlet nozzle.

**Suction** – Pumping action begins when vapor, gases, or liquid in the suction chamber are entrained by the high velocity stream emerging from the inlet nozzle, lowering the pressure in the suction chamber. The resulting action causes the liquid, gas, or vapor in the suction chamber to flow toward the discharge.

**Discharge** - The entrained material from the suction system mixes with the operating medium and acquires part of its energy

in the parallel section. In the diffuser section part of the velocity of the mixture is converted to a pressure greater than the suction pressure, but lower than the operating medium pressure.

## The advantages of jets for pumping gases

Penberthy Jet Pumps offer many advantages over other methods in pumping gases:  
They have no moving parts, nothing to break or wear.

No lubrication is required. They are practically noiseless in operation. The initial cost is low. Installation cost is low because they are compact and no foundation or wiring is necessary. They provide reliable operation with low maintenance cost.

## Jet pump gas handling applications

There are numerous possible applications for Penberthy Jet Pumps in handling gases. Jet pumps are commonly found in

these industries: textile, chemical, food, water treatment, petroleum, research, distilling, brewing.

Specific gas handling applications include: gas-air mixers, crystallization, vacuum filters, fluid concentration, as condensers, fume removal, solvent extraction systems, drying, vacuum impregnation, distillation, condensed air removal, de-aeration

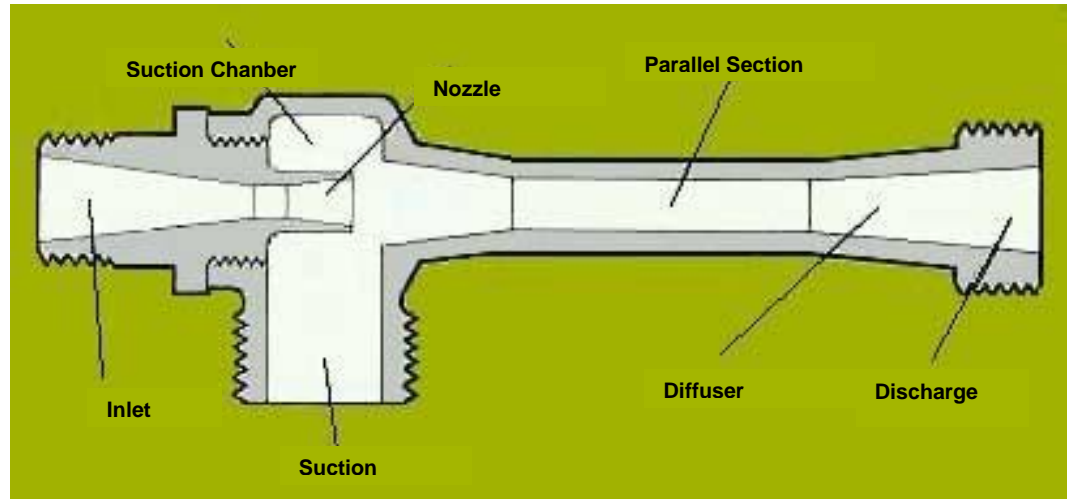

## TYPICAL APPLICATIONS

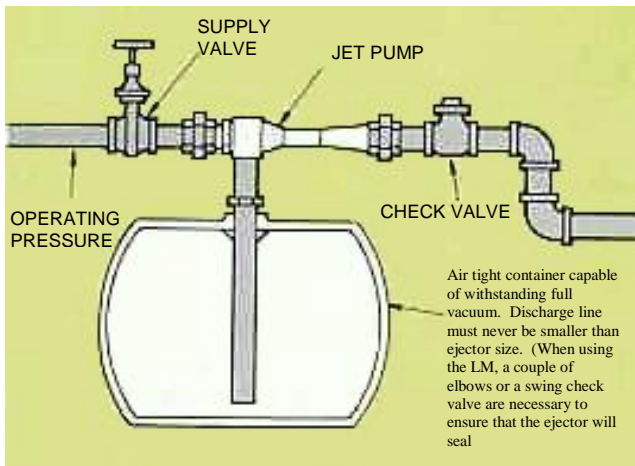

Producing a vacuum

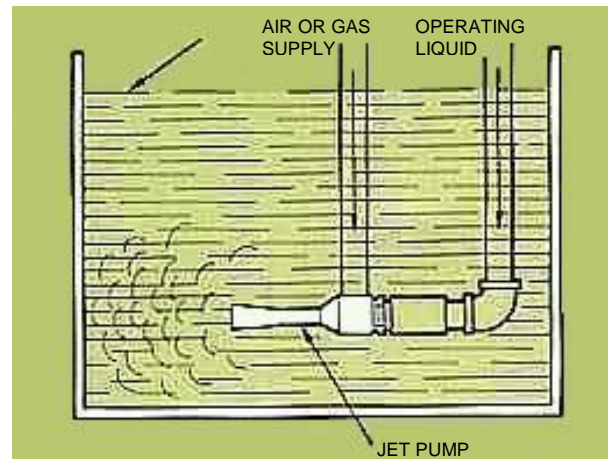

Aeration or agitation

# applications and selection

## TYPICAL APPLICATIONS (cont.)

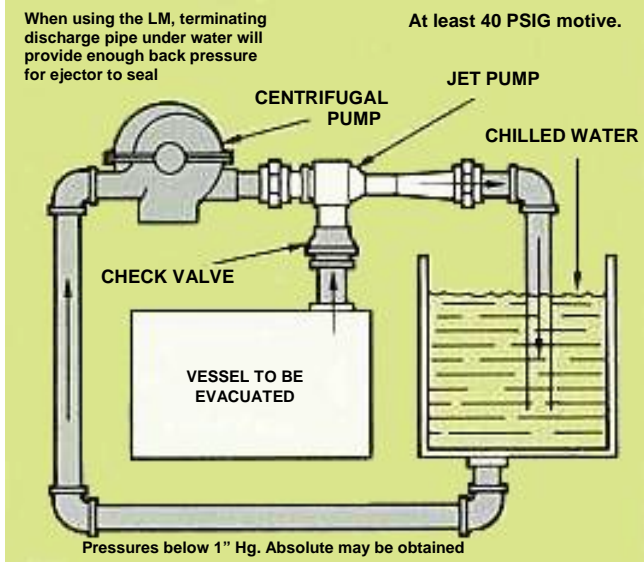

**Producing the best possible vacuum**

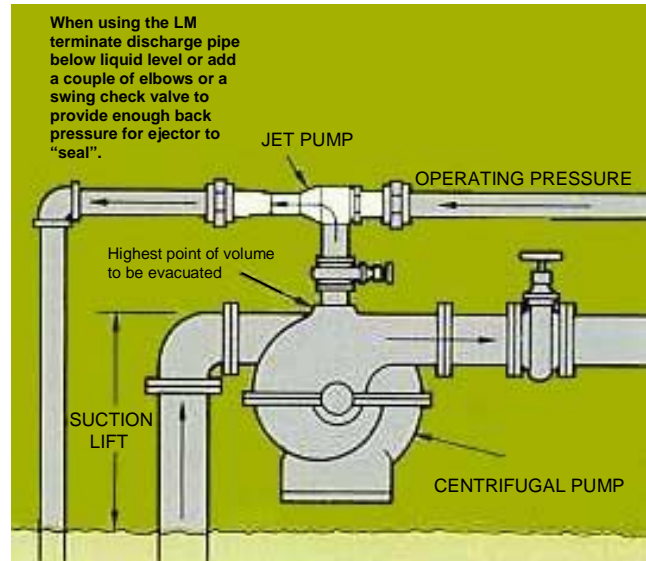

**Priming centrifugal pumps**

## PUMPING GASES

Using steam, air or liquid as operating medium

Refer to the table below for operating parameters of the jet pumps used for pumping gases. These jets are used to purge gases from chambers, exhaust, evacuate and prime.



	MODEL LM	MODEL ELL	MODEL FL	MODEL GL	MODEL GH
Operating medium	Liquid	Liquid	Liquid	Steam, air	Steam, air
Operating medium pressure range	20 – 200 PSIG	20 – 200 PSIG	20 – 100 PSIG	60 – 120 PSIG	20 – 80 PSIG
Application range, inches HG.ABS.	1 - 27	1 - 27	27 – 30	6 – 30	6.5 – 30
Functions	Evac / Exh / Prime	Evac / Exh / Prime	Exh	Evac / Exh / Prime	Evac / Exh / Prime

	MODEL U	MODEL L	MODEL 2NC
Operating medium	Steam	Steam	Steam
Operating medium pressure range	80 – 200 PSIG	80 – 200 PSIG	100 – 200 PSIG
Application range, inches HG.ABS.	6 – 12	3 – 6	0.5 – 3
Functions	Evac / Exh	Evac / Exh	Evac / Exh

# LM, ELL and FL models

## PUMPING LIQUIDS USING LIQUID OPERATING MEDIUM

The LM and ELL Jet Pumps are used for exhausting, evacuating and priming operations where a liquid operating medium is available in a 20 to 200 PSIG pressure range. The maximum vacuum with closed suction is one inch HG ABS. These models are available with suction and discharge fittings ranging from 1/2 to 12 inches —depending on the type of construction.

Cast – (1/2 to 6") Fabricated – (4 to 12") Molded – (3/4 to 1 1/2") PVC – (1/2 to 3")  
The Model FL "Fume Movers" operate in facilities where the liquid operating medium is available in the 20 to 100 PSIG range. They are identical in principle to the LM and ELL units but differ in their "Water Consumption to Capacity" ratio. Where the ELL Model requires more

than 2 GPM of operating fluid for each SCFM of air pumped, the FL with 2 GPM can pump approximately 14 SCFM of air. The other distinguishing factor is the capacity of the FL Models to move large volumes of air at a suction pressure just slightly below atmospheric. The ELL is more well-suited for moving air at a suction pressure of 1/2 to 1/10 atmospheric pressure – about 13

times the vacuum of the FL Fume Mover. FL Models are available with flanged suction and discharge fittings ranging from 1/2 to 4" and nozzle size ranging from 1/2 to 3: depending on the type of unit selected.

### EVACUATING AND PRIMING\* (Models LM, ELL)

First determine: EXAMPLE

- Volume of Space to be Evacuated – ft<sup>3</sup> .....30 ft<sup>3</sup>
  - Required Evacuation Time – minutes .....3 min.
  - Operating Liquid Pressure – PSIG (hm) .....80 PSIG
  - Discharge Pressure Required – PSIG (hd) .....atmospheric
- (Refer to LM, ELL Evacuation Time Chart)

**Step 1** – Determine evacuation time in minutes per 10 ft<sup>3</sup> or 100 ft<sup>3</sup> depending on volume of space to be evacuated (in this case, 30 ft<sup>3</sup> – otherwise expressed as .3 hundred ft<sup>3</sup>).

$$\frac{\text{Required Time to Evacuate (3 Min.)}}{\text{Evacuation time}/100 \text{ ft}^3 (.3)} = 10 \text{ min.}/100 \text{ ft}^3$$

**\*Priming** The procedure for selecting Jet Pumps for Priming Applications is the same as that for Evacuation except:

It takes twice the time to prime the same volume that can be evacuated with a given jet.

**Step 2** – Locate Operating Water Pressure (in this case 80 PSIG) and Suction Pressure (in this case 5" HG ABS) on the left side of the chart.

**Step 3** – Following along the appropriate line into the "100 ft<sup>3</sup> Evacuated" section, find the Evacuation Time that's "equal to or lower than" the Evacuation Time requirement expressed in minutes/100 ft<sup>3</sup> (in this case 10 minutes for ELL 2).

**Step 4** – Continuing to the right on the same line, you'll find the Operating Water Used for the selected model (in this case 32.5 GPM for the ELL 1 1/2").

Then multiply this figure times the ELL 2 Capacity Factor (C.F.) to determine the Actual Water Consumption of the selected unit.

$$\frac{32.5}{\text{GPM Operating Water Used}} \times \frac{1.82}{\text{(C.F.)}} = 59.2 \text{ Actual Water Consumption}$$

### LM, ELL EVACUATION TIME

Operating Water Pressure (hm)	Suction Pressure HG. Abs. (hs)	TIME IN MINUTES PER																Operating Water Used GPM (Qm)					
		10 CUBIC FEET EVACUATED				100 CUBIC FEET EVACUATED																	
		1/2" A		1/2" B		1/2"		3/4"		1"		1 1/4"		1 1/2"		2"			2 1/2"		3"		1 1/2"
LM	ELL	LM	ELL	LM	ELL	LM	ELL	LM	ELL	LM	ELL	LM	ELL	LM	ELL	LM	ELL	LM	ELL	LM	ELL		
20 PSIG	25"	24	13	15	8.3	59	32	34	19	21	11	12	6.4	7.1	3.9	3.9	2.1	2.2	1.2	1.2	.66	17.5	17.2
	20"	87	50	55	32	215	123	125	72	76	43	43	24	26	15	14	8.2	8.2	4.7	4.4	2.5	18.4	18.1
	15"	180	107	114	68	448	264	260	154	157	93	88	52	54	32	30	18	17	10	9.1	5.4	19.2	18.8
	10"					826		481		291		163		100		55		31		17		20.0	
40 PSIG	25"	8.3	6	5.3	3.8	21	15	12	8.7	7.3	5.2	4.1	2.9	2.5	1.8	1.4	.99	.79	.57	.42	.30	24.2	23.0
	20"	33	22	21	14	83	55	48	32	29	19	16	11	10	6.7	5.6	3.7	3.2	2.1	1.7	1.1	24.8	23.6
	15"	83	50	53	32	208	124	121	72	73	43	41	24	25	15	14	8.2	7.9	4.7	4.2	2.5	25.4	24.2
	10"	157	90	100	57	392	223	228	130	138	78	77	44	47	27	26	15	15	8.5	8.0	4.5	26.0	24.7
60 PSIG	5"	320	163	204	104	793	405	461	236	279	143	157	80	96	49	53	27	30	15	16	8.3	26.6	25.3
	25"	3.7	4.7	2.3	3	91	12	5.3	6.7	3.2	4.1	1.8	2.3	1.1	1.4	.60	.77	.35	.44	.18	.24	29.4	27.3
	20"	17	14	11	9.1	41	36	24	21	14	12	8.1	7	5	4.3	2.7	2.4	1.6	1.3	.84	.72	30.0	27.8
	15"	43	30	28	19	110	74	64	43	39	26	22	15	13	8.9	7.3	4.9	4.2	2.8	2.2	1.5	30.5	28.3
80 PSIG	10"	97	50	62	32	240	124	139	72	84	44	47	24	29	15	16	8.2	9.1	4.7	4.9	2.5	30.9	28.7
	5"	207	87	132	55	512	215	298	125	180	76	101	43	62	26	34	14	19	8.2	10	4.4	31.4	29.2
	25"	2.3	3.7	1.5	2.3	5.8	9.1	3.4	5.3	2	3.2	1.1	1.8	0.7	1.1	.38	.60	.22	.35	.11	.18	33.8	30.9
	20"	11	11	7	7	27	27	15.9	16	9.6	9.5	5.4	5.3	3.3	3.3	1.8	1.8	1.0	1.0	.55	.55	34.2	31.3
100 PSIG	15"	26	22	17	14	64	54	37.5	31	23	19	13	11	7.8	6.5	4.3	3.6	2.4	2.0	1.3	1.1	34.7	31.7
	10"	60	37	38	23	153	91	89	53	54	31	30	17	18	11	10	5.9	5.8	3.4	3.1	1.8	35.1	32.1
	5"	143	60	91	38	355	149	207	87	125	54	70	30	43	18	24	10	13	5.8	7.2	3.1	35.6	32.5
	25"	2.2	3.3	1.4	2.1	5.4	8.3	3.1	4.8	1.9	2.9	1.1	1.6	.65	1.0	.36	.55	.20	.31	.11	.17	37.7	34.0
140 PSIG	20"	7.7	9	4.9	5.7	19	22	11	13	6.7	7.9	3.7	4.4	2.3	2.7	1.3	1.5	.72	.86	.39	.46	38.1	34.4
	15"	19	18	12	11	48	44	28	25	17	15	9.5	8.7	5.8	5.3	3.2	2.9	1.8	1.7	.98	.90	38.5	34.7
	10"	40	29	25	19	99	73	58	42	35	25	20	14	12	8.8	6.6	4.8	3.8	2.8	2.0	1.5	38.9	35.1
	5"	100	50	64	32	249	124	145	72	88	44	49	25	30	15	17	8.3	9.5	4.7	5.1	2.5	39.3	35.4
140 PSIG	25"	2	2.7	1.3	1.7	4.9	6.6	2.9	3.8	1.7	2.3	.98	1.3	.60	.80	.33	.44	.19	.25	.10	.13	44.5	39.4
	20"	4.7	7	3	4.5	12	17	6.7	10	4.1	6.2	2.3	3.5	1.4	2.1	.77	1.2	.44	.68	.24	.36	44.8	39.6
	15"	11	13	7.2	8.5	28	33	16	19	9.6	12	5.5	6.6	3.4	4.0	1.9	2.2	1.1	1.3	.57	.68	45.2	40.0
	10"	24	23	15	14	59	56	35	33	21	20	12	11	7.2	6.8	4.0	3.7	2.3	2.1	1.2	1.1	45.5	40.2
5"	47	40	30	26	118	99	69	58	41	34	23	19	14	12	7.9	6.4	4.5	3.7	2.4	2.0	45.9	40.6	

## Exhausting (Models LM, ELL, FL)

First determine:

EXAMPLE

Suction Load – SCFM air (Qs) ..... 1.3 SCFM  
 Suction Pressure – Inches Hg. ABS (hs).....15"  
 Operating Liquid Pressure, PSIG (hm).....60 PSIG  
 Discharge Pressure, PSIG (hd).....5 PSIG  
*(Refer to FL Exhauster and 1½ LM and ELL Exhauster Comparative Performance Chart.)*

- Step 1** – Locate appropriate Suction Pressure (in this case 15") on left side of chart and the line that applies to existing Water Pressure (in this case 60 PSIG).
- Step 2** – Read across the 60 PSIG line to the 5 PSIG Discharge Pressure column noting – LM Suction Capacity .....1.4 SCFM  
 ELL Suction Capacity .....3.1 SCFM
- Step 3** – Following along the same line you'll note  
 Operating Water Used .....28.3 GPM
- Step 4** – Since the ELL 1½ was the unit with the greater suction capacity in comparison to our requirement, we'll use it in computing the Ideal Capacity Factor (C.F.)
- $$\frac{\text{Desired Capacity (1.3 SCFM)}}{\text{Suction Capacity – ELL 1½ (3.1 SCFM)}} = .419 \text{ (Ideal C.F.)}$$

Then using the Capacity Factor Chart, find the size unit that provides a capacity factor that's equal to or greater than .419 (Ideal C.F.)

The actual capacity of the selected unit is then determined by multiplying:

$$3.1 \text{ (ELL 1½ SCFM Per Chart)} \times .613 \text{ (ELL 1¼ Capacity Factor)} = 1.90 \text{ SCFM}$$

- Step 5** – To determine Water Consumption of the selected unit, multiply:

$$28.3 \text{ (GPM Operating Water Used)} \times .613 \text{ (Selected unit C.F.)} = 17.3 \text{ GPM}$$

- Step 6** – In checking the capacity and consumption of the other unit considered, we find that the LM 1 ½, with a capacity of 1.4 SCFM, has a water consumption rate of 28.3 GPM. It then becomes obvious that the ELL 1¼ is the best unit for this application as it delivers the greatest capacity with the least volume of water consumed.

- Step 7** – FL MODELS ONLY – The connecting discharge line must be sized to handle both the operating liquid and entrained air without producing more than a few inches of water discharge pressure. If this cannot be done, a box, tank or separator should be provided at the discharge end to separate non-condensable washed gases from the liquid and to vent washed gases to the atmosphere.

## LM, ELL CAPACITY FACTOR

SIZE	½ A	½ B	½	¾	1	1¼	1½	2	2½	3	4	6	8	10	12
FACTOR	.030	.047	.121	.208	.344	.613	1.00	1.82	3.17	5.92	11.8	24	49	71	123

## FL 51 CAPACITY FACTOR

SIZE	1 A	1 B	1½	2	2½	3	4
FACTOR	.3	.48	1.00	1.6	2.7	4.9	9.2

## FL 101 CAPACITY FACTOR

SIZE	1½ A	1½ B	2	3	4A	4B
FACTOR	.69	1.00	1.6	3.2	5	9

## 1½ LM & ELL EXHAUSTERS COMPARATIVE PERFORMANCE

Suction Pressure HG. Abs. (hs)	Operating Water Pressure (hm)	SUCTION CAPACITY IN SCFM AT DISCHARGE PRESSURE BELOW (QS)										Oper Water GPM (Qm)
		0 PSIG		5 PSIG		10 PSIG		15 PSIG		20 PSIG		
		LM	ELL	LM	ELL	LM	ELL	LM	ELL	LM	ELL	
30" (Atmospheric)	20	8.0	7.0									16.4
	40	10.0	9.0	2.5	5.0							22.5
	60	13.0	12.0	3.8	8.0	3.0	6.0					26.9
	80	14.0	13.0	5.5	10.0	3.9	8.5	3.2	7.2	2.9		30.6
	100	18.0	14.0	10.0	13.0	5.8	11.0	4.4	9.5	3.6	8.6	33.8
	140	19.0	18.0	13.0	16.0	8.5	15.0	6.2	14.0	5.6	13.0	39.2
200	21.0	19.0	19.0	18.0	16.0	18.0	11.0	18.0	8.6	17.0	45.0	
40	1.6	3.0										17.2
60	3.6	5.6	1.7	3.5								23.0
80	5.8	8.0	2.8	5.9	2.2	4.6						27.3
100	8.4	10.2	3.9	8.0	3.0	6.7	2.5	5.8	2.2			30.9
140	9.9	11.4	6.1	10.0	4.1	9.0	3.4	7.9	3.0	7.3		34.0
200	12.6	14.5	8.4	13.7	6.1	13.0	5.0	11.9	4.5	11.2		39.4
40	0.9	1.6										18.1
60	1.9	3.6	1.2	2.4								23.6
80	3.3	5.7	2.1	4.4	1.6	3.5						27.8
100	4.9	7.8	2.8	6.3	2.3	5.2	1.9	4.6	1.6			31.3
140	6.2	8.8	4.0	7.7	3.1	7.2	2.6	6.4	2.3	6.0		34.4
200	8.9	11.3	5.6	10.8	4.4	10.2	3.8	9.6	3.4	9.1		39.6
40	0.5	0.8										18.8
60	1.1	2.4	0.8	1.5								24.2
80	1.8	3.9	1.4	3.1	1.1	2.6						28.3
100	2.5	5.3	1.9	4.9	1.6	3.8	1.4	3.5	1.1			31.7
140	3.7	6.3	2.5	5.9	2.2	5.4	1.9	5.0	1.6	4.6		34.7
200	5.3	8.4	3.4	8.0	3.0	7.6	2.6	7.3	2.4	7.1		40.0
40	0.6	1.3	0.5									24.7
60	0.9	2.6	0.8	2.0	0.7	1.5						28.7
80	1.3	3.5	1.2	3.0	1.0	2.7	0.9	2.4	0.7			32.1
100	2.0	3.9	1.4	3.8	1.3	3.7	1.2	3.5	1.1	3.3		35.1
140	2.6	5.9	2.0	5.6	1.8	5.4	1.6	5.3	1.4	5.3		40.2
200	5.1	7.0	3.7	6.9	2.8	6.8	2.4	6.7	2.2	6.6		45.9
40	0.3	0.6	0.3									25.3
60	0.4	1.6	0.3	1.2	0.3							29.2
80	0.7	2.0	0.5	1.7	0.5	1.5	0.4	1.0	0.2			32.5
100	0.8	2.2	0.6	2.1	0.6	2.1	0.6	2.0	0.6	1.9		35.4
140	1.2	3.1	1.0	3.0	0.8	2.9	0.8	2.9	0.8	2.9		40.6
200	2.0	3.5	1.5	3.5	1.2	3.5	0.9	3.5	0.9	3.5		46.2

## FL FUME MOVER COMPARATIVE PERFORMANCE

Suction Pressure Inches Water Vacuum (hs)	Operating Water Pressure (hm)	Capacity in SCFM At Atmospheric Discharge (Qs)				Operating Water Consumption GPM (Qm)	
		FL 51 1 1/2"	FL 101 1 1/2"B	FL 51 1 1/2"	FL 101 1 1/2"B		
0" (Atmospheric)	20	24.6	21.9	10.5	3.5		
	40	36.5	29.3	14.0	4.8		
	60	43.8	37.0	16.7	5.7		
	80	51.1	41.3	18.9	6.4		
	100	58.6	46.9	20.8	7.0		
5"	20	14.6	-	10.5	-		
	40	29.6	10.0	14.0	4.8		
	60	38.1	21.1	16.7	5.7		
	80	46.1	29.9	18.9	6.4		
	100	54.2	37.1	20.8	7.0		
10"	20	6.7	-	10.5	-		
	40	23.0	-	14.0	-		
	60	32.6	6.8	16.7	5.7		
	80	41.2	18.5	18.9	6.4		
	100	50.0	27.5	20.8	7.0		
15"	40	16.9	-	14.0	-		
	60	27.2	-	16.7	-		
	80	36.6	7.0	18.9	6.4		
	100	45.9	17.0	20.8	7.0		
	20"	40	11.5	-	14.0	-	
60		22.2	-	16.7	-		
80		32.2	-	18.9	-		
100		41.8	7.8	20.8	7.0		
25"		40	7.0	-	14.0	-	
	60	17.7	-	16.7	-		
	80	28.0	-	18.9	-		
	100	38.7	-	20.8	-		
	30"	40	3.3	-	14.0	-	
60		13.7	-	16.7	-		
80		24.3	-	18.9	-		
100		34.2	-	20.8	-		
35"		40	0.4	-	14.0	-	
	60	10.5	-	16.7	-		
	80	20.9	-	18.9	-		
	100	30.6	-	20.8	-		
	45"	40	-	-	-	-	
60		4.8	-	16.7	-		
80		14.8	-	18.9	-		
100		24.4	-	20.8	-		

# LM, ELL and FL models

Note: Always specify material, model and unit size

## CAST - LM, ELL

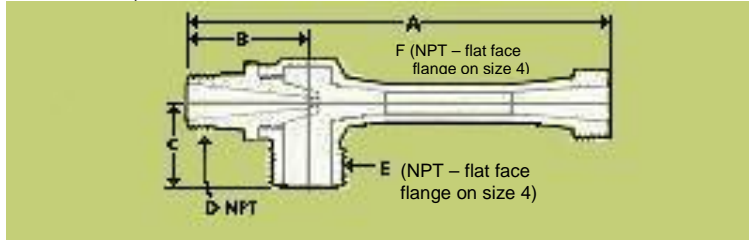

Size		A	B	C	D	E	F
1/2 A	LM	4 3/8	1 1/2	1 1/4	1/4	1/2	1/2
1/2 B	LM, ELL	4 3/8	1 1/2	1 1/4	1/4	1/2	1/2
1/2	LM, ELL	4 1/2	1 5/8	1 1/4	3/8	1/2	1/2
3/4	LM, ELL	5 1/8	2	1 1/2	1/2	3/4	3/4
1	LM, ELL	7 1/8	2 1/4	1 3/4	3/4	1	1
1 1/4	LM, ELL	9	2 1/2	2 1/4	1	1 1/4	1 1/4
1 1/2	LM, ELL	11	2 3/4	2 1/2	1	1 1/2	1 1/2
2	LM, ELL	14 3/8	3 1/8	3	1 1/4	2	2
2 1/2	LM, ELL	18 1/8	3 1/2	4 1/8	1 1/2	2 1/2	2 1/2
3	LM, ELL	23 7/8	4	5	2	3	3
4	LM, ELL	32 7/8	5	6	3	4flange*	4flange*

\*Bolting corresponds to ASA 150 lbs.

## MOLDED - LM, ELL

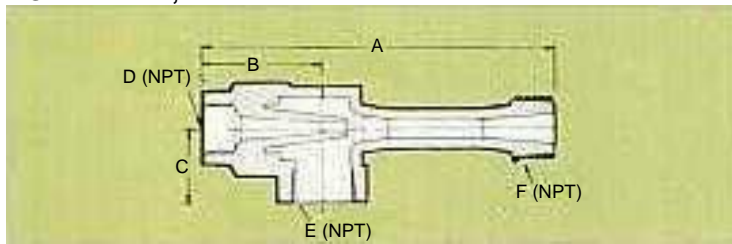

Size		A	B	C	D	E	F
3/4	LM	5 15/16	2	1 1/4	1/2	3/4	3/4
1	LM, ELL	7 1/4	2 1/4	1 1/2	3/4	1	1
1 1/4	LM, ELL	9 3/8	2 11/16	1 7/8	1	1 1/4	1 1/4
1 1/2	LM, ELL	11 7/16	3	2 1/16	1 1/4	1 1/2	1 1/2

## PVC - LM, ELL

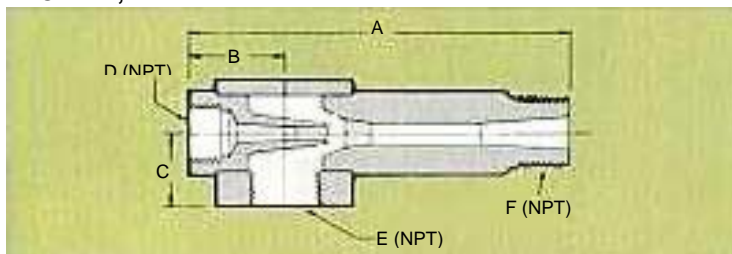

Size		A	B	C	D	E	F
1/2 A	LM	3 3/4	1 11/16	15/16	1/4	1/2	1/2
1/2 B	LM	3 3/4	1 11/16	13/16	1/4	1/2	1/2
1/2	LM	4 5/8	1 11/16	15/16	1/4	1/2	1/2

3/4	LM	5 3/4	1 1/8	1	1/2	3/4	3/4
1	LM, ELL	6 7/8	2 1/8	1 5/16	3/4	1	1
1 1/4	LM, ELL	9 1/16	2 3/4	1 1/2	1	1 1/4	1 1/4
1 1/2	LM, ELL	10 15/16	3	1 3/4	1	1 1/2	1 1/2
2	LM, ELL	14 3/16	3 1/2	1 15/16	1 1/4	2	2
2 1/2	LM, ELL	18 1/2	4	2 1/2	1 1/2	2 1/2	2 1/2
3	LM, ELL	24 3/16	4 1/2	3	2	3	3

## FABRICATED - LM, ELL

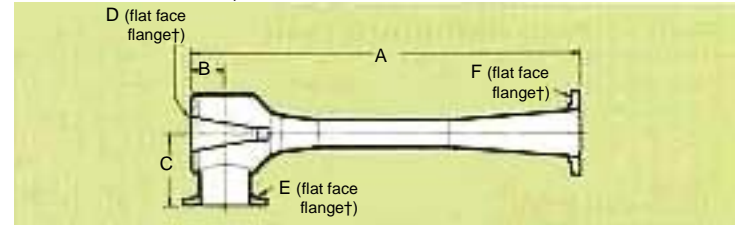

Size	A	B	C	D†	E†	F†
4	38 1/4	5 1/4	8	3	4	4
6	52 7/8	5 7/8	9 1/2	4	6	6
8	74 7/16	8 7/16	13	6	8	8
10	87 3/8	10 3/8	14	8	10	10
12	110 3/4	11 3/4	18	10	12	12

†Bolting corresponds to ASA 150 lbs. Bolt holes in D flange of all sizes are blind tapped

## CAST - FL

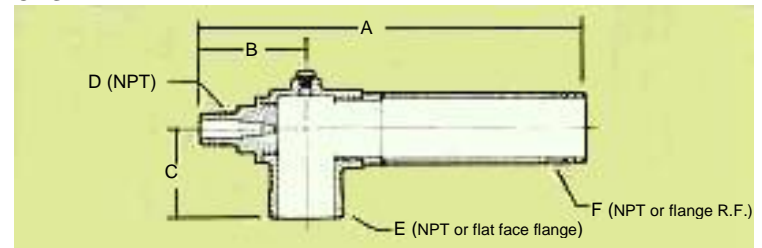

## FL51

Size	Nozzle Sizes	A	B	C	D	E	F
1A	3/4	11 7/8	2 1/2	1 1/4	1/2	1	1
1B	1	11 7/8	2 1/2	1 3/4	3/4	1	1
1 1/2	1 1/4	16 9/16	3	2 1/2	1	1 1/2	1 1/2
2	1 1/2	20 11/16	3 3/4	3	1	2	2
2 1/2	2	25 7/8	3 3/4	4 1/8	1 1/4	2 1/2	2 1/2
3	2 1/2	33 15/16	4 1/4	5	1 1/2	3	3
4	3	45	5	6	2	4	4

## FL101

Size	Nozzle Sizes	A	B	C	D	E	F
1 1/2 A	1/2	10 5/16	2 13/16	2 1/2	3/8	1 1/2	1 1/2
1 1/2 B	3/4	10 5/16	2 13/16	2 1/2	1/2	1 1/2	1 1/2
2	1	12 3/4	3 1/4	3	3/4	2	2
3	1 1/4	17 9/16	4	5	1	3	3
4A	1 1/2	26 1/8	5	6	1	4	4
4B	2	26 1/8	5	6	1 1/4	4	4

# dry air equivalent

## DAE CONVERSIONS FOR GL, GH, U, L AND 2NC MODELS

Performance curves for Penberthy Steam-Air Ejectors are plotted in terms of suction pressure and suction gas flow, lb./hr. 70 °F dry air equivalent. Most ejector application data does not include suction gas rate as lb./hr. 70 °F dry air equivalent, but rather the suction gas rate is presented at some other temperature and for some gas or combination of gases of a composition different from that of air.

Since it is not practical for a manufacturer of steam jet ejectors to maintain facilities for testing ejectors with all the numerous suction gas mixtures and all the many temperatures for which ejectors are used, a method has been devised to permit the design and test of ejectors using air at normal room temperatures or air and steam at any temperature convenient for the manufacturer. The Heat Exchange Institute (HEI) provides a standard that is used and accepted by manufacturers and users of ejectors. Material used in this explanation is adapted from the **Standards for Steam Jet Ejectors** as published by the Heat Exchange Institute.

It is important for all persons involved in the application of Penberthy Ejectors to be conversant with the method of changing any load gas to its dry air equivalent at 70 °F.

**To Determine Average Molecular Weight** – Gas mixtures are presented in terms of lb./hr. or can be converted to these terms. Steam or water vapor may be contained in a mixture of gases and vapors, however it is treated as a separate component because temperature correction is different from that of other gases. The following example illustrates the most complex conversion that one might encounter:  
 Given: 100 lb./hr. of a mixture of gases and vapor at 200 °F temperature, consisting of 20 lb./hr. of carbon dioxide gas, 30 lb./hr. of air, 5 lb./hr. of hydrogen and 45 lb./hr. of water vapor.

Molecular weights are as follows:  
 CO<sub>2</sub> = 44 lb./mol  
 Air = 29 lb./mol  
 H<sub>2</sub> = 2 lb./mol  
 H<sub>2</sub>O = 18 lb./mol

Find average molecular weight of the mixture except for water vapor:

$$\begin{aligned} &20 \text{ lb./hr. CO}_2 \div 44 \text{ lb./mol} = 0.455 \text{ mol/hr.} \\ &30 \text{ lb./hr. Air} \div 29 \text{ lb./mol} = 1.035 \text{ mol/hr.} \\ &5 \text{ lb./hr. H}_2 \div 2 \text{ lb./mol} = 2.500 \text{ mol/hr.} \\ &55 \text{ lb./hr. mixture} \div 3.990 \text{ mol/hr.} = 13.8 \text{ lb./mol} \end{aligned}$$

$$\text{Avg. M.W.} = \frac{55 \text{ lb./hr.}}{3.99 \text{ mol/hr.}} = 13.8 \text{ lb./mol}$$

**Molecular Weight Conversion Factors (29 MW = 1.0)**  
 Use same gas as given above and curve no. 1:

Cmw correction factor for 13.8 mw = 0.7

Cmw correction factor for 18 (H<sub>2</sub>O) = 0.81

**Temperature Conversion Factors (70 °F = 1.0)** – Use same gas as above and curve no. 2.

Ct temperature correction for 13.8 mw gas at 200 °F (use curve for air) = 0.968

Ct temperature correction for steam at 200 °F = 0.957

**Actual Conversion** – Use factors from above as follows to find the 70 °F Dry Air Equivalent of 100 lb./hr. of a mixture of gas and water vapor all at 200 °F and consisting of 20 lb./hr. of CO<sub>2</sub> plus 30 lb./hr. of air plus 5 lb./hr. of H<sub>2</sub> plus 45 lb./hr. of H<sub>2</sub>O.

$$\frac{(20 + 30 + 5)}{0.7 \times 0.968} +$$

$$\frac{45}{0.81 \times 0.957} =$$

$$82 + 58 = 140 \text{ lb./hr.}$$

Therefore an ejector that will pump the specified gas load of 100 lb./hr. at 200 °F must also be able to pump 140 lb./hr. of air at 70 °F.

**NOTE: Do not confuse DAE with noncondensable gas load!**

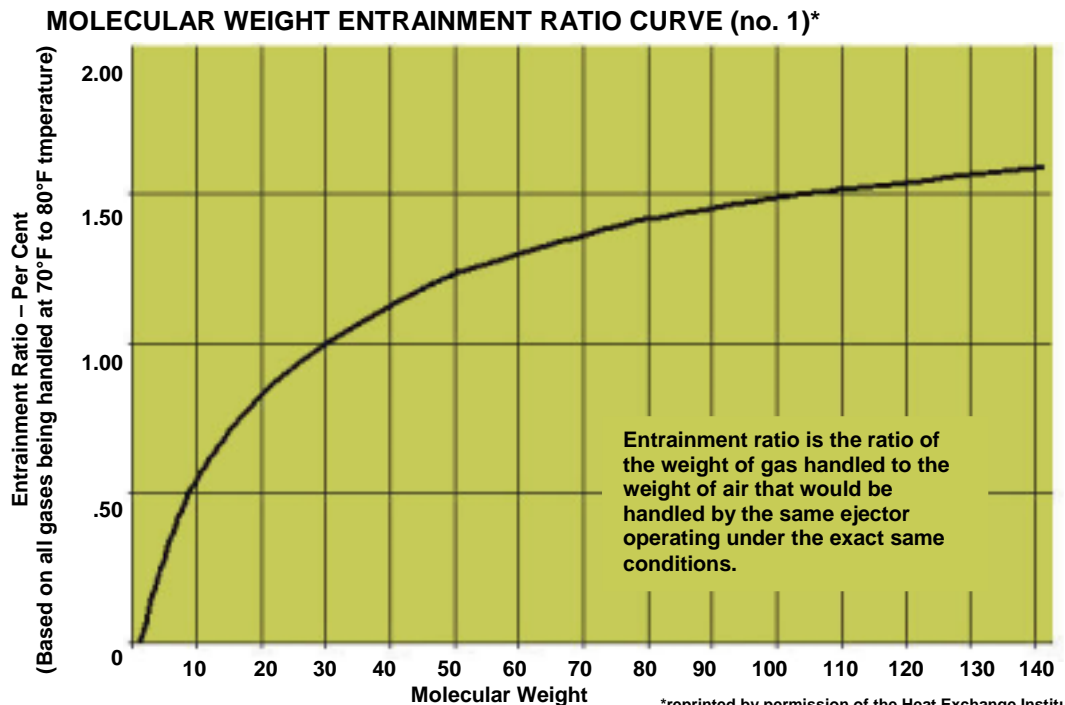
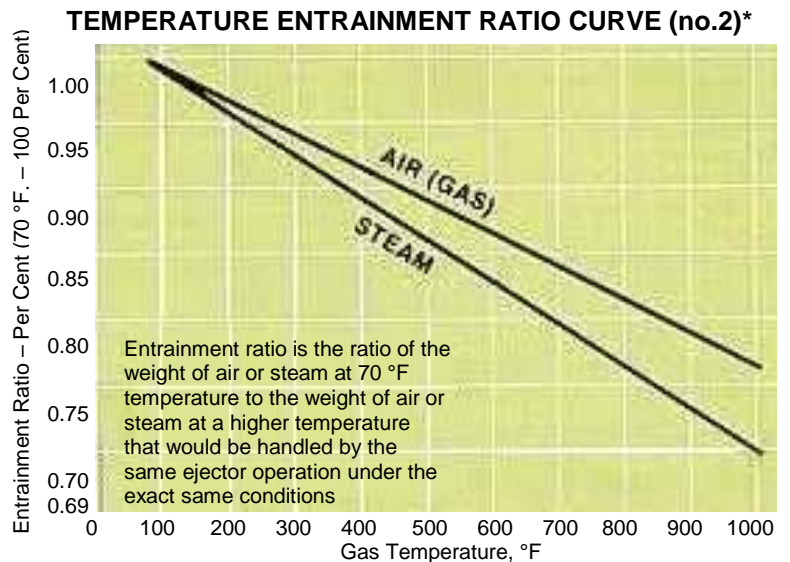

\*reprinted by permission of the Heat Exchange Institute.

# GL, GH models

## PUMPING GASES USING STEAM OR AIR OPERATING MEDIUM

The Series G jet pumps include the GL and GH models. They are used for exhausting, evacuating and priming applications. The Model GL uses operating steam or air from 60 to 120 PSIG. The maximum vacuum with closed suction is 6 inches HG. ABS. The Model GH uses operating steam or air from 20 to 80 PSIG. The maximum vacuum with closed suction is 6.5 inches HG. ABS. The capacities of both models are slightly higher when using air as the operating medium instead of steam. The following information is required for selection of both the GL and GH Models for exhausting, evacuating and priming.

### Exhausting:

- Suction load, Standard Cubic Feet per Minute (SCFM) air (Qs)\*
- Suction pressure, inches HG. ABS. (hs)
- Operating steam or air pressure, PSIG (hm)
- Discharge pressure required, PSIG (hd)

\* For suction loads other than air, refer to Dry Air Equivalent section on page 7. To convert suction load data from ACFM or lbs./hr. to SCFM, see section on page 16.

### Evacuating:

- Suction load, in cubic feet of space to be evacuated
- Required time to evacuate, in minutes
- Operating steam or air pressure, PSIG (hm)
- Final suction pressure, inches HG. ABS. (hs)
- Discharge pressure required, PSIG (hd)

### Priming:

The selection procedure for ejectors in priming applications is the same as that for evacuation, except: The evacuation time must be doubled for priming applications because the priming capacity of any given ejector is half that of the evacuating capacity.

### G SERIES unit selection using performance charts

The following procedures and examples are included for selecting Series G Jet Pumps. Refer to the performance curves

and tables when determining individual unit sizes.

For air operating medium, use the same performance data as for steam.

To estimate the air consumption in standard cubic ft./minute, divide the listed values by 3. For example: The GH-1½ steam consumption is 497 lbs./hr. at 60 psig. The air consumption at the same pressure would be  $497 \div 3 = 166$  SCFM.

### Exhausting – selection procedure

**Step 1** – From the family of performance curves, select the one matching the available Operating Pressure, PSIG (hm) and required Discharge Pressure, PSIG (hd).

**Step 2** – At the point where this curve intersects the Suction Pressure (hs), read down the line to determine Suction Capacity (Qs) of 1½ inch unit.

**Step 3** – Compute ideal Capacity Factor (C.F.) by dividing:

$$\frac{Q_s - \text{Required}}{Q_s - \text{From Curve}}$$

**Step 4** – Select (from C.F. chart) the unit having C.F. equal to or greater than that determined in Step 3.

**Step 5** – To figure steam consumption, refer to Steam Consumption table. Find the consumption listed for available Operating Pressure (hm) and multiply this by the C.F. for the selected unit.

### Evacuating – selection procedure

**Step 1** – Compute time in minutes per hundred cubic feet to complete the required evacuation.

**Step 2** – Refer to the GL, GH Evacuation Time Chart. Find the Operating Pressure (hm) and Suction Pressure (hs).

**Step 3** – Read across to the right and find the unit that will complete the evacuation within the desired time.

**Step 4** – To figure steam consumption, multiply the Steam Used (shown in the right-hand column of the same chart) by the appropriate Capacity Factor (C.F.).

### Exhausting – EXAMPLE:

To exhaust 200 SCFM:

Suction Pressure, inches HG. ABS. (hs) .....20  
Operating Steam Pressure, PSIG (hm) .....80  
Maximum Discharge Pressure, PSIG (hd) .....5  
Both GL and GH Models are considered in this example to illustrate selection on the basis of operating economy.

**Step 1** – Go to the 80 PSIG curves (hm) and note discharge pressure of each.

**Step 2** – These curves intersect suction pressures (hs) at :  
35.5 SCFM on the GL – 1½ Curve  
17.0 SCFM on the GH – 1½ Curve

**Step 3** – Ideal Capacity Factor (C.F.)

$$\frac{Q_s - \text{Required}}{Q_s - \text{From Curve}}$$
$$\text{GL} - 1\frac{1}{2} = \frac{200}{35.5} = 5.63$$

$$\text{GH} - 1\frac{1}{2} = \frac{200}{17.0} = 11.76$$

**Step 4** – From the C.F. chart

$$\text{GL} - 3 = 5.92$$
$$\text{GH} - 4 = 11.8$$

**Step 5** – To determine the most economical model of those considered, check Steam Consumption chart and determine the steam consumption of both under available Operating Pressure 80 PSIG:

GL-3 uses 277 lbs./hr. x C.F. 5.92 = 1640 lbs./hr.  
Maximum Discharge Pressure (from curve) = 6 PSIG  
GH-4 uses 623 lbs./hr. x C.F. 11.8 = 7351 lbs./hr.  
Maximum Discharge Pressure (from curve) = 21 PSIG

**Therefore:** the GL-3, having the lower steam consumption, in the desired range of operation, is the correct unit.

NOTE: GL and GH PVC units are for air operation only.

### Evacuating – EXAMPLE:

To evacuate 200 cubic feet in 30 minutes:

Final Suction Pressure, inches HG. ABS. (hs) .....10  
Operating Steam Pressure, PSIG (hm) .....40  
Discharge Pressure (hd) .....atmospheric

**Step 1** – Determine time in minutes per 100 cubic feet to complete evacuation:

$$\frac{30 \text{ minutes total}}{2 \text{ (hundred ft}^3)} = 15 \text{ minutes per 100 cubic feet}$$

**Step 2** – Locate Operating Steam Pressure, 40 PSIG (hm) and Suction Pressure, 10 inches HG. ABS. (hs) on Evacuation Time chart.

**Step 3** – Read across to the right and locate unit that will complete evacuation in desired time. The GH-1 will complete the evacuation in 14 minutes.

**Step 4** – Find Steam Used in right-hand column – 366 lbs./hr. Multiply this by the C.F. for the GH-1:  
.344 x 366 lbs./hr. = 126 lbs./hr.

## GL, GH EVACUATION TIME

Operating Water Pressure (hm)	Suction Pressure In. HG. Abs. (hs)	TIME IN MINUTES PER																				Operating Steam Used LBS./HR. (Qm)
		10 CUBIC FEET EVACUATED				100 CUBIC FEET EVACUATED																
		1/2" A		1/2" B		1/2"		3/4"		1"		1 1/4"		1 1/2"		2"		2 1/2"		3"		
GL	GH	GL	GH	GL	GH	GL	GH	GL	GH	GL	GH	GL	GH	GL	GH	GL	GH	GL	GH	GL	GH	
30 PSIG	25"	2.4	1.5	6.0	3.5	2.1	1.2	0.73	0.40	0.23	0.12	301										
	20"	4.7	3.0	12.0	6.7	4.1	2.3	1.4	0.77	0.44	0.24	301										
	15"	8.7	5.5	21.0	12.0	7.5	4.2	2.6	1.4	0.82	0.44	301										
	10"	15.0	9.6	37.0	22.0	13.0	7.3	4.5	2.5	1.4	0.76	301										
40 PSIG	25"	1.7	1.1	4.1	2.4	1.4	0.81	0.50	0.27	0.16	0.08	366										
	20"	4.0	2.5	9.9	5.8	3.5	2.0	1.2	0.66	0.38	0.20	366										
	15"	8.3	5.3	21.0	12.0	7.3	4.1	2.5	1.4	0.79	0.42	366										
	10"	15.7	10.0	39.0	23.0	14.0	7.7	4.7	2.6	1.5	0.79	366										
60 PSIG	25"	1.0	0.64	1.1	2.5	1.4	2.4	0.87	1.4	0.49	0.81	0.30	0.50	0.16	0.27	0.09	0.16	0.05	0.08	221	497	
	20"	2.3	1.5	3.0	5.8	12.0	3.4	6.7	2.0	4.1	1.1	2.3	0.70	1.4	0.38	0.77	0.22	0.44	0.12	0.24	221	497
	15"	4.0	2.5	6.0	9.9	23.0	5.8	13.0	3.5	8.1	1.9	4.6	1.2	2.8	0.66	1.5	0.38	0.88	0.20	0.47	221	497
	10"	7.7	4.9	12.0	19.0	47.0	11.0	27.0	6.7	17.0	3.7	9.3	2.3	5.7	1.3	3.1	0.72	1.8	0.39	0.96	221	497
80 PSIG	25"	1.0	0.64	1.3	2.5	1.4	2.9	0.87	1.7	0.49	0.98	0.30	0.60	0.16	0.33	0.09	0.19	0.05	0.10	277	623	
	20"	2.0	1.3	3.2	5.0	12.0	2.9	7.2	1.7	4.4	0.98	2.4	0.60	1.5	0.33	0.82	0.19	0.47	0.10	0.25	277	623
	15"	4.0	2.5	6.2	9.9	24.0	5.8	14.0	3.5	8.4	2.0	4.7	1.2	2.9	0.66	1.6	0.38	0.91	0.20	0.49	277	623
	10"	8.0	5.1	13.0	20.0	50.0	11.0	29.0	7.0	17.0	3.9	9.8	2.4	6.0	1.3	3.3	0.76	1.9	0.40	1.0	277	623
100 PSIG	25"	1.0	0.64	1.3	2.5	1.4	2.9	0.87	1.7	0.49	0.98	0.30	0.60	0.16	0.33	0.09	0.19	0.05	0.10	333	750	
	20"	2.3	1.5	3.4	5.8	13.0	3.4	7.7	2.0	4.6	1.1	2.6	0.70	1.6	0.38	0.88	0.22	0.50	0.12	0.27	333	750
	15"	4.7	3.0	7.4	12.0	29.0	6.7	17.0	4.1	10.0	2.3	5.7	1.4	3.5	0.77	1.9	0.44	1.1	0.24	0.59	333	750
	10"	8.7	5.5	26.0	21.0	99.0	12.0	58.0	7.6	35.0	4.3	20.0	2.6	12.0	1.4	6.6	0.82	3.8	0.44	2.0	333	750
120 PSIG	25"	1.0	0.64	2.5	1.4	0.87	0.49	0.30	0.16	0.09	0.05	390										
	20"	2.7	1.7	6.6	3.8	2.3	1.3	0.80	0.44	0.25	0.13	390										
	15"	5.3	3.4	13.0	7.7	4.6	2.6	1.6	0.88	0.50	0.27	390										
	10"	9.0	5.7	22.0	13.0	7.8	4.4	2.7	1.5	0.85	0.46	390										

## 1 1/2 GL, GH SUCTION AIR LOAD SCFM (Qs) PERFORMANCE CURVES (EXHAUSTING)

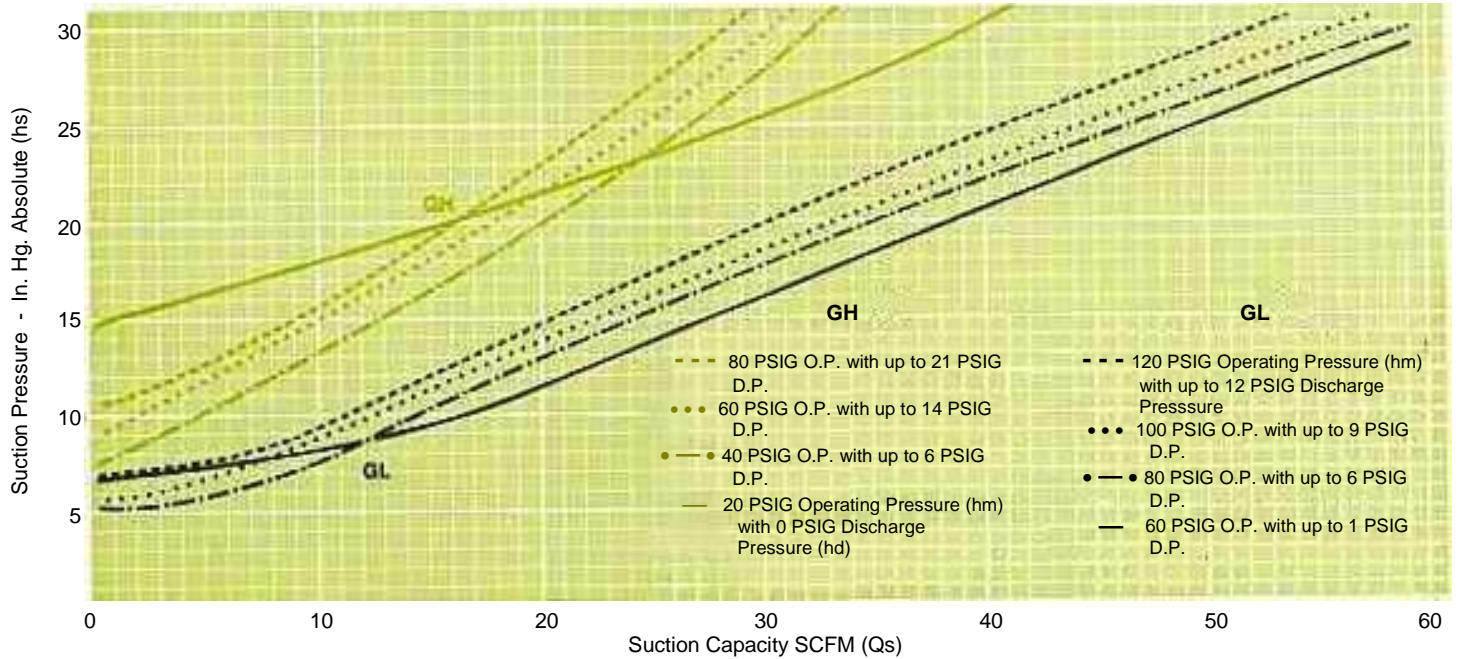

### 1 1/2 GL, GH STEAM CONSUMPTION (lbs. / hr. Qm)

STEAM PRES. (hm)	20	40	60	80	100	120	150
GL			221	277	333	390	474
GH	236	366	497	623	750	878	1067

### 1 1/2 GL, GH AIR CONSUMPTION (SCFM)

AIR PRES. (hm)	20	40	60	80	100	120	150
GL			74	92	111	130	158
GH	78	122	166	208	250	293	356

### GL, GH CAPACITY FACTOR

SIZE	1/2 A	1/2 B	1/2	3/4	1	1 1/4	1 1/2	2	2 1/2	3	4	6	8	10	12
FACTOR	.030	.047	.121	.208	.344	.613	1.00	1.82	3.17	5.92	11.8	24	49	71	123

### G SERIES Sizes available

Each model is available in 15 sizes from 1/2 to 12 inches suction and discharge. Units are cast construction in sizes 1/2 through 6. Sizes 4 through 12 are available with fabricated construction. Certain sizes of units are also available in PVC

or molded construction as shown in the charts on the following page.

NOTE: Always specify material, model and unit size when ordering. For available materials, check **Penberthy Material Specification Sheet**.

# GL, GH models

## CAST – GL, GH

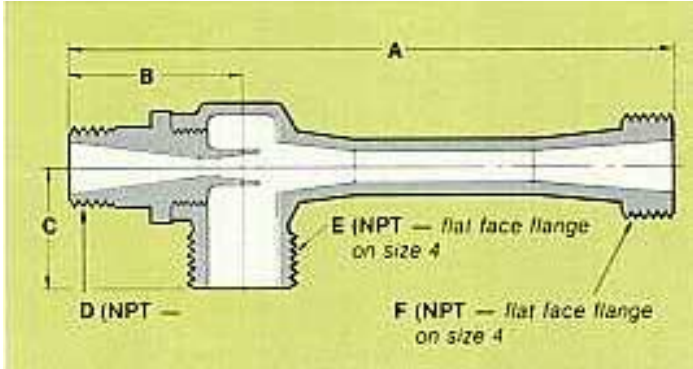

### CAST – GL, GH DIMENSIONS (in inches)

SIZE	A	B	C	D*	E*	F*
1/2 A	4 3/8	1 1/2	1 1/4	1/4	1/2	1/2
1/2 B	4 3/8	1 1/2	1 1/4	1/4	1/2	1/2
1/2	4 1/2	1 5/8	1 1/4	3/8	1/2	1/2
3/4	5 1/8	2	1 1/2	1/2	3/4	3/4
1	7 1/8	2 1/4	1 3/4	3/4	1	1
1 1/4	9	2 1/2	2 1/4	1	1 1/4	1 1/4
1 1/2	11	2 3/4	2 1/2	1	1 1/2	1 1/2
2	14 3/8	3 1/8	3	1 1/4	2	2
2 1/2	18 1/8	3 1/2	4 1/8	1 1/2	2 1/2	2 1/2
3	23 7/8	4	5	2	3	3
4	32 7/8	5	6	3	4flange*	4flange*

\*Bolting corresponds to ASA 150 lbs.

## MOLDED – GL, GH

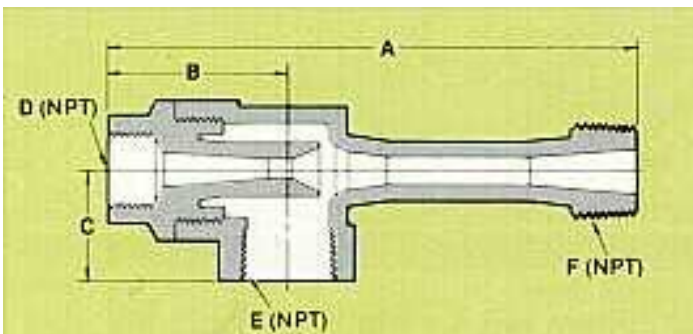

### MOLDED – GL, GH DIMENSIONS (in inches)

Size	A	B	C	D	E	F
3/4	5 15/16	2	1 1/4	1/2	3/4	3/4
1	7 1/4	2 1/4	1 1/2	3/4	1	1
1 1/4	9 3/8	2 11/16	1 7/8	1	1 1/4	1 1/4
1 1/2	11 7/16	3	2 1/16	1 1/4	1 1/2	1 1/2

## FABRICATED – GL, GH

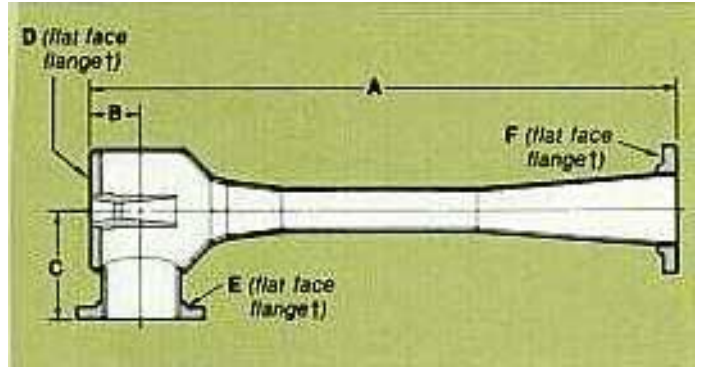

### FABRICATED – GL, GH DIMENSIONS (in inches)

Size	A	B	C	D†	E†	F†
4	38 1/4	5 1/4	8	3	4	4
6	52 7/8	5 7/8	9 1/2	4	6	6
8	74 7/16	8 7/16	13	6	8	8
10	87 3/8	10 3/8	14	8	10	10
12	110 3/4	11 3/4	18	10	12	12

†Bolting corresponds to ASA 150 lbs. Bolt holes in D flange of all sizes are blind tapped.

## PVC – GL, GH (for air operation only)

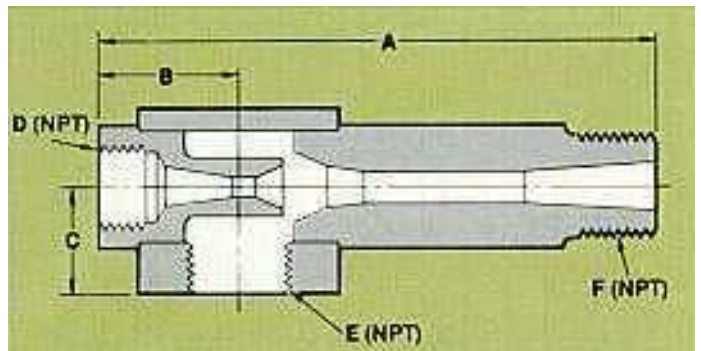

### PVC – GL, GH DIMENSIONS (in inches)

Size	A	B	C	D	E	F
1/2 A	3 3/4	1 11/16	15/16	1/4	1/2	1/2
1/2 B	3 3/4	1 11/16	15/16	1/4	1/2	1/2
1/2	4 5/8	1 11/16	15/16	1/4	1/2	1/2
3/4	5 3/4	1 1/8	1	1/2	3/4	3/4
1	6 7/8	2 1/8	1 5/16	3/4	1	1
1 1/4	9 1/16	2 3/4	1 1/2	1	1 1/4	1 1/4
1 1/2	10 15/16	3	1 3/4	1	1 1/2	1 1/2
2	14 3/16	3 1/2	1 15/16	1 1/4	2	2
2 1/2	18 1/2	4	2 1/2	1 1/2	2 1/2	2 1/2
3	24 3/16	4 1/2	3	2	3	3

# U, L, 2NC models

## PUMPING GASES USING STEAM OPERATING MEDIUM

**Model U and L Single Stage Ejectors** are available in 16 capacities and suction sizes from 1 inch to 6 inches. The Model U operates efficiently in a vacuum range of 6 to 12 inches HG. ABS. While the Model L operates efficiently in the range of 3 to 6 inches HG. ABS. These ejectors are used for exhausting and evacuating applications where steam is the operating medium in the range of 80 to 200 psig.

**The 2NC Two Stage Non-Condensing Ejectors** are also available in 16 capacity ranges for similar applications in a vacuum range of .5 to 3 inches HG. ABS. The 2NC uses steam as the operating medium in the range of 100 to 200 PSIG.

**Nozzles supplied with U, L and 2NC Ejectors** are selected by Penberthy to match the operating steam pressure specified when units are ordered. Nozzles are available for operating steam pressures of 80 (for U and L only), 100, 120, 140, 160, 180 or 200 PSIG.

Steam consumption data given in charts in this section are valid for any one of these pressures. When the operating steam pressure specified falls between two of these standard pressures, Penberthy will supply the lower pressure nozzle. Steam consumption will be slightly higher for such units unless the operating steam pressure is regulated to match that of the nozzle.

The following information is required for selection of these three steam operated models in exhausting and evacuating applications.

### Exhausting:

- Suction load (Qs) lbs./hr. of dry air at 70 °F, or Dry Air Equivalent (DAE) (For suction loads other than air, refer to Dry Air Equivalent section on page 7.)
  - Air – pounds per hour
  - Water Vapor – pounds per hour
  - Molecular weights and quantities of other suction gases – pounds per hour

- Suction pressure, inches HG. ABS. (hs)
- Operating steam pressure, PSIG (hm)
- Discharge pressure, PSIG (hd) (if greater than 1 PSIG, contact factory)

### Evacuating:

- Suction Load, in cubic feet of air to be evacuated  
Required time to evacuate, in minutes
- Operating steam pressure, PSIG (hm)
- Final suction pressure, inches HG. ABS (hs)
- Discharge pressure required, PSIG (hd)

For evacuating applications using Model L or Model 2NC, contact Penberthy

### U, L, 2NC unit selection using performance charts

The following procedures and examples are included for selecting U, L and 2NC ejectors. Refer to the performance curves and tables to determine individual unit sizes.

### Exhausting –

#### Selection procedure

Refer to U, L Performance Curves on pages 12 and 13.

**Step 1** – Determine unit having suction pressure within application range.

**Step 2** – Determine capacity of selected unit using the following procedure:

- Refer to required Suction Pressure (hs) in left-hand column.
- Read across to Operating Steam Pressure curve (hm). Read down this line and note the Suction Capacity at the bottom of chart.

**Note:** both U and L curves are drawn for U-4 and L-4 units. Capacity Factors are used to determine capacities of all other units.

**Step 3** – Calculate the ideal Capacity Factor:  
Ideal C.F. =

$$\frac{\text{Desired Capacity}}{\text{Capacity from curve}}$$

**Step 4** – Choose unit with capacity factor equal to or greater than the ideal.

**Step 5** – Refer to Capacity Factor Chart and note Operating Steam Consumption (Qm) for selected unit.

The selection procedure for Model 2NC is identical to that for Models U and L. Use 2NC Performance Curves and Steam Consumption Chart.

### Evacuating –

#### Selection procedure

Refer to U Evacuation Time chart.

**Step 1** – Figure evacuation time in minutes per hundred cubic feet.

*Continued*

### Exhausting – Example

To exhaust 55 pounds of 70°F dry air per hour:

Suction Pressure, inches Hg ABS (hs).....	6
Operating Steam Pressure, PSIG (hm).....	160
Discharge Pressure, PSIG (hd).....	1

**Step 1** – Consider both U-4 and L-4 units based on Suction Pressure of 6 inches Hg ABS.

**Step 2** – Starting at 6 (hs) on curve, read across to required Operating Steam Pressure (hm). Read down this vertical line and note Suction Capacity (Qs) at bottom.

U-4 Capacity is 84 lbs. per hour  
L-4 Capacity is 85 lbs. per hour

**Step 3** – Calculate Ideal Capacity Factor:

$$\frac{\text{Desired Capacity}}{\text{Capacity from curve}} = \text{for U} - 4 \frac{55 \text{ lbs/hr}}{84} = .655$$

$$= \text{for L} - 4 \frac{55 \text{ lbs/hr}}{85} = .647$$

**Step 4** – Choose the exact unit size having a C.F. equal to or greater than the ideal.

Both Models U-3 and L-3 have a C.F. of .694.

U-3 Capacity = .694 x 84 (from Step 2) = 58.2 lbs/hr

L-3 Capacity = .694 x 85 = 58.9 lbs/hr

This particular example illustrates the close performance characteristics of both U and L Models at the Suction Pressure of 6 inches Hg ABS. In this case, the Model U is operating in the lower end of its application range and its performance improves at Suction Pressures above 6. The Model L, however, is operating in the upper extreme of the application range and performance improves at Suction Pressures below 6.

**Step 5** – Note Operating Steam Consumption (Qm) on Capacity Factor Chart. Model U-3 and L-3 Steam Consumption = 195 lbs/hr.

### Evacuating – Example:

To evacuate 3000 cubic foot vessel full of air at atmospheric pressure:	
Operating Steam Pressure, PSIG (hm).....	100
Final Suction Pressure, inches Hg ABS. (hs).....	5
Time to evacuate, hrs.....	2.5
Discharge Pressure (hd).....	atmosphere

**Step 1** – Determine evacuation time in minutes per hundred cubic feet.

$$\frac{2.5 \text{ hours} \times 60}{30 (\text{hundred}) \text{ feet}^3} = 5 \text{ minutes} / 100 \text{ cubic feet}$$

**Step 2** – Go to the final pressure on left of Evacuation Time chart (5 in. HG. hs). Read across and find evacuation time equal to or less than 5 minutes.

The U-2 will evacuate the tank in 5.33 minutes per hundred cubic feet and the U-3 will complete the evacuation in 3.42 minutes per cubic hundred feet.

**Step 3** – Read steam consumption of selected unit off Capacity Factor Chart. The unit to select would be the U-3 in this case and its steam consumption is 195 lbs/hr.

# U, L, 2NC models

**Step 2** – go to the left-hand column in table, final Suction Pressure (hs). Read across to find evacuation time equal to or less than that determined in Step 1. Read to the top of the table and note unit number.

**Step 3** – Read Steam Consumption of unit selected off Capacity Factor Chart.

## U, L and 2NC Model Sizes Available

Each model is available in 16 sizes from 1 inch to 4 inches suction and discharge. Sizes 1 through 3 are NPT. Size 4 is drilled in accordance with ASA 125 lbs. bolt pattern.

**NOTE:** When ordering, always specify operating steam pressure, for correct nozzle sizing. Also specify material, model and unit size. For available materials, check **Penberthy Material Specification Sheet**.

## U MODEL EVACUATION TIME (in minutes per 100 cu. ft at 100 PSIG Operating Steam Pressure)

SUCTION PRESS. IN. HG ABS. (hs)	MODEL NUMBER															
	U-1H	U-2H	U-3H	U-4H	U-5H	U-6H	U-7H	U-8H	U-9H	U-10H	U-11H	U-12H	U-13H	U-14H	U-15H	U-16H
12"	4.680	3.080	1.980	1.370	1.010	0.769	0.610	0.494	0.409	0.343	0.293	0.253	0.206	0.171	0.145	0.123
11"	5.060	3.320	2.140	1.480	1.090	0.830	0.657	0.532	0.441	0.370	0.316	0.273	0.222	0.185	0.156	0.133
10"	5.440	3.570	2.300	1.590	1.170	0.894	0.707	0.572	0.474	0.398	0.340	0.293	0.239	0.198	0.168	0.143
9"	5.850	3.840	2.460	1.710	1.260	0.960	0.760	0.615	0.510	0.427	0.365	0.315	0.257	0.213	0.180	0.154
8"	6.290	4.140	2.660	1.840	1.350	1.040	0.818	0.662	0.549	0.460	0.393	0.339	0.276	0.230	0.194	0.165
7"	6.760	4.450	2.860	1.980	1.460	1.120	0.880	0.771	0.590	0.495	0.423	0.365	0.297	0.247	0.209	0.178
6"	7.350	4.840	3.100	2.150	1.580	1.210	0.955	0.774	0.640	0.537	0.460	0.396	0.323	0.268	0.227	0.193
5"	8.100	5.330	3.420	2.370	1.740	1.330	1.060	0.853	0.706	0.592	0.507	0.437	0.356	0.295	0.250	0.213
4"	9.320	6.130	3.940	2.730	2.010	1.540	1.220	0.981	0.813	0.683	0.584	0.504	0.410	0.340	0.288	0.245
3"	11.600	7.600	4.870	3.380	2.480	1.900	1.500	1.220	1.010	0.845	0.721	0.623	0.507	0.422	0.356	0.304

## U AND L CAPACITY FACTOR AND STEAM CONSUMPTION

MODEL NUMBER	L-1H	L-2H	L-3H	L-4H	L-5H	L-6H	L-7H	L-8H	L-9H	L-10H	L-11H	L-12H	L-13H	L-14H	L-15H	L-16H
	U-1H	U-2H	U-3H	U-4H	U-5H	U-6H	U-7H	U-8H	U-9H	U-10H	U-11H	U-12H	U-13H	U-14H	U-15H	U-16H
<b>CAPACITY FACTOR</b>	0.293	0.445	0.694	1.00	1.36	1.78	2.25	2.78	3.36	4.00	4.69	5.43	6.66	8.03	9.49	11.12
<b>OPERATING STEAM CONSUMPTION LB. PER HOUR (Qm)</b>	85	125	195	270	370	480	610	755	910	1090	1280	1480	1820	2190	2580	3030

(Valid at standard nozzle pressure of 80, 100, 120, 140, 160, 180 or 200 PSIG)

## 2NC CAPACITY FACTOR AND STEAM CONSUMPTION

MODEL NUMBER	2NC 1H	2NC 2H	2NC 3H	2NC 4H	2NC 5H	2NC 6H	2NC 7H	2NC 8H	2NC 9H	2NC 10H	2NC 11H	2NC 12H	2NC 13H	2NC 14H	2NC 15H	2NC 16H
	<b>CAPACITY FACTOR</b>	0.293	0.445	0.694	1.00	1.36	1.78	2.25	2.78	3.36	4.00	4.69	5.43	6.66	8.03	9.49
<b>OPERATING STEAM CONSUMPTION LB. PER HOUR (Qm)</b>	106	160	240	330	450	590	740	920	1110	1320	1525	1800	2200	2660	3140	3660

(Valid at standard nozzle pressure of 100, 120, 140, 160, 180 or 200 PSIG)

## U-4H PERFORMANCE CURVES

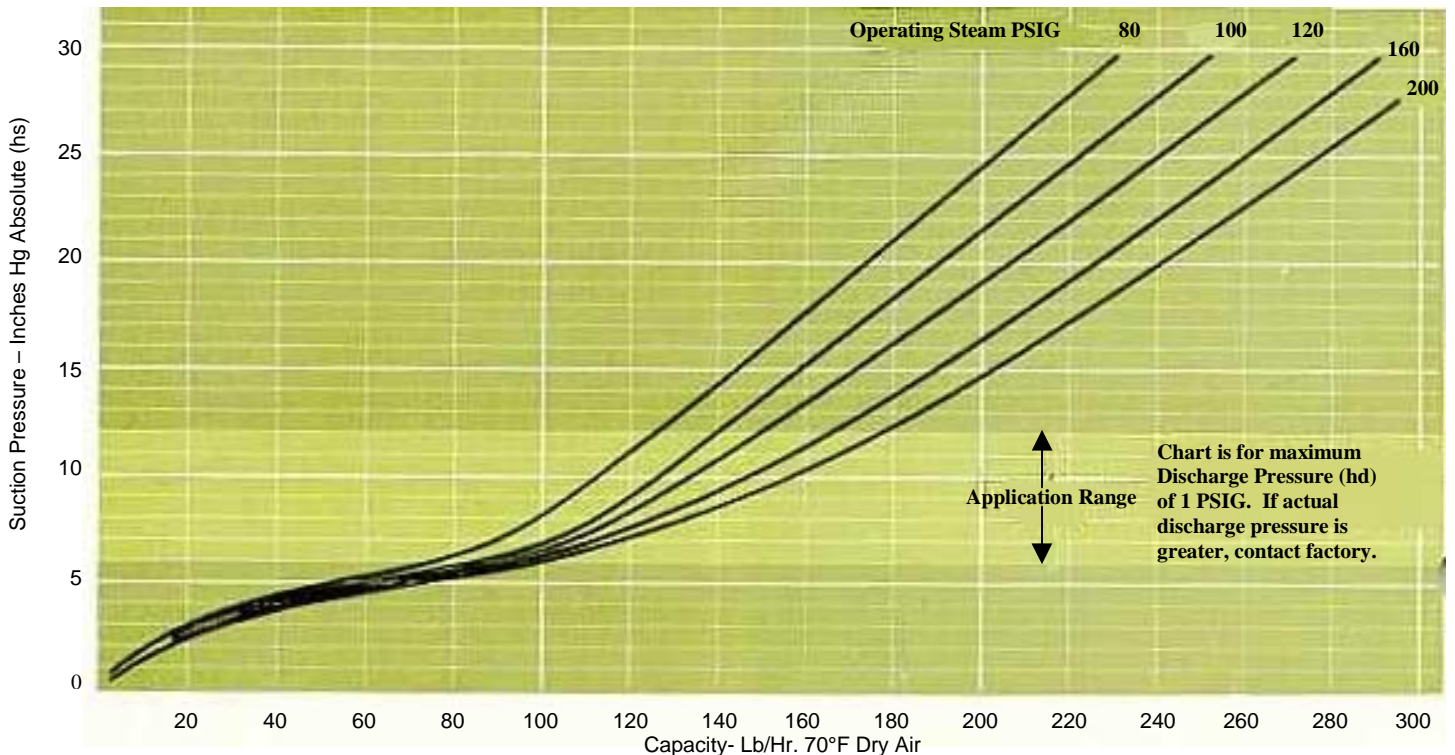

**L-4H PERFORMANCE CURVES**

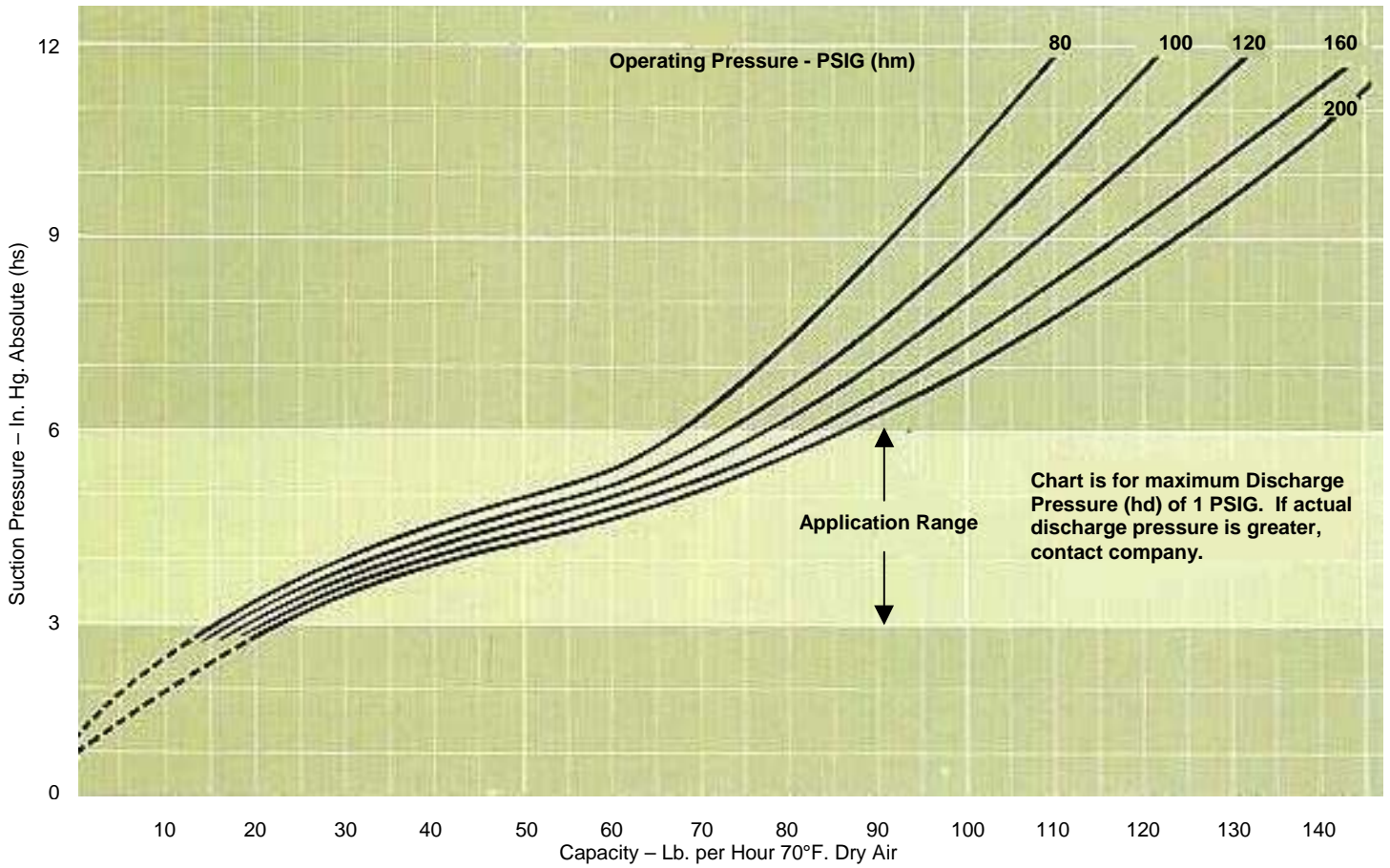

**2NC-4H PERFORMANCE CURVES**

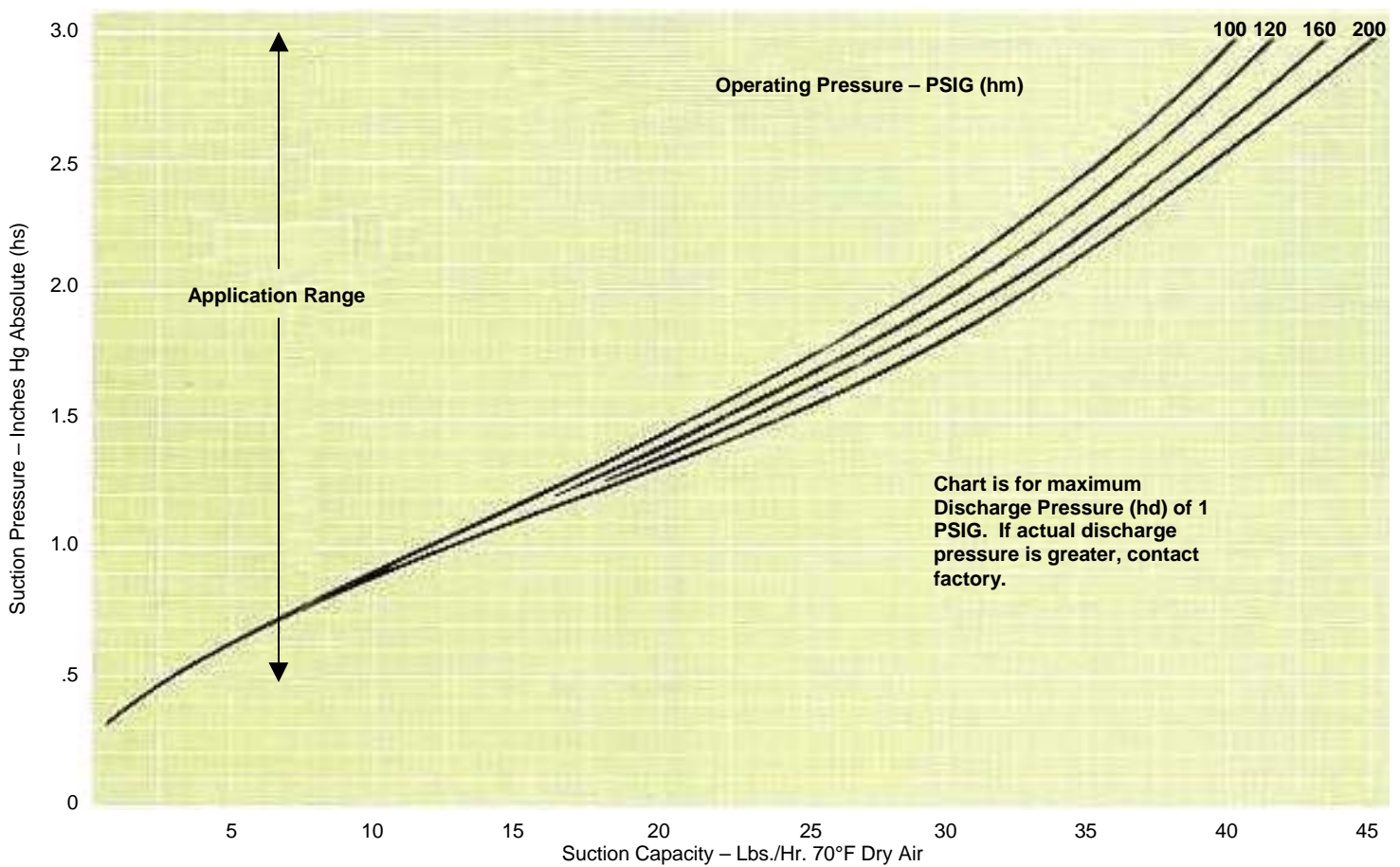

**CAST – U AND L**

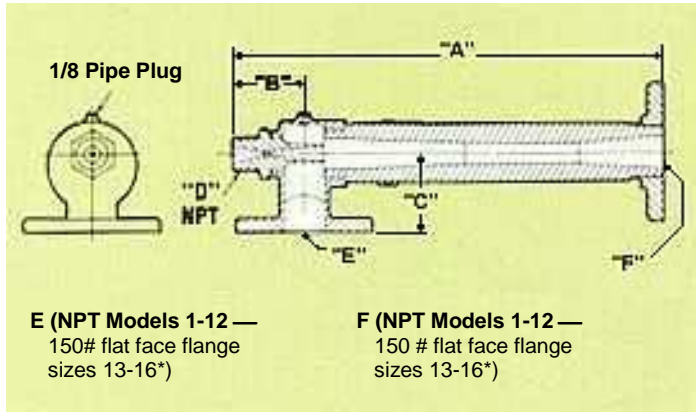

**CAST – U AND L DIMENSIONS**

Model	Dimensions In Inches					
	"A"	"B"	"C"	"D"	"E"	"F"
L-1H, U-1H	9 ¼	2 ¼	1 ¾	½	1	1
L-2H, U-2H	10 ¾	2 ¼	1 ¾	½	1	1
L-3H, U-3H	13 ½	2 ¾	2 ½	1	1 ½	1 ½
L-4H, U-4H	15 ½	2 ¾	2 ½	1	1 ½	1 ½
L-5H, U-5H	18 1/8	3 1/8	3	1 ¼	2	2
L-6H, U-6H	20 1/8	3 1/8	3	1 ¼	2	2
L-7H, U-7H	22 ¾	3 ½	4 1/8	1 ½	2 ½	2 ½
L-8H, U-8H	24 ¾	3 ½	4 1/8	1 ½	2 ½	2 ½
L-9H, U-9H	27 ½	4	5	2	3	3
L-10H, U-10H	29 ½	4	5	2	3	3
L-11H, U-11H	31 ½	4	5	2	3	3
L-12H, U-12H	33 ½	4	5	2	3	3
L-13H, U-13H	38 1/8	5	6	3	4	4
L-14H, U-14H	41 1/8	5	6	3	4	4
L-15H, U-15H	45	5 7/8	6	3	4	4
L-16H, U-16H	47 ½	5 7/8	6	3	4	4

**CAST – 2NC**

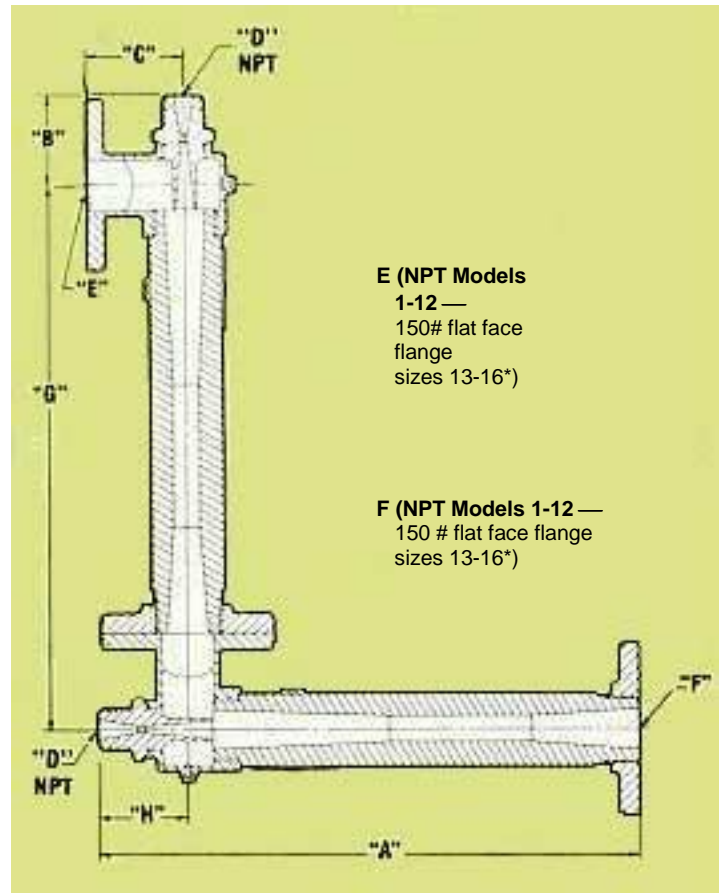

**CAST – 2NC DIMENSIONS**

Model	Dimensions In Inches							
	"A"	"B"	"C"	"D"	"E"	"F"	"G"	"H"
2NC1H	9¼	2¼	1¾	½	1	1	10 <sup>1</sup> / <sub>8</sub>	2 ¼
2NC2H	10¾	2¼	1¾	½	1	1	11 <sup>5</sup> / <sub>8</sub>	2 ¼
2NC3H	13½	2¾	2½	1	1½	1½	15¼	2 ¾
2NC4H	15½	2¾	2½	1	1½	1½	17¼	2 ¾
2NC5H	18 <sup>1</sup> / <sub>8</sub>	3 <sup>1</sup> / <sub>8</sub>	3	1¼	2	2	19 <sup>7</sup> / <sub>8</sub>	3 <sup>1</sup> / <sub>8</sub>
2NC6H	20 <sup>1</sup> / <sub>8</sub>	3 <sup>1</sup> / <sub>8</sub>	3	1¼	2	2	21 <sup>7</sup> / <sub>8</sub>	3 <sup>1</sup> / <sub>8</sub>
2NC7H	22¾	3½	4 <sup>1</sup> / <sub>8</sub>	1½	2½	2½	25¼	3 ½
2NC8H	24¾	3½	4 <sup>1</sup> / <sub>8</sub>	1½	2½	2½	27¼	3 ½
2NC9H	27½	4	5	2	3	3	30¾	4
2NC10H	29½	4	5	2	3	3	32¾	4
2NC11H	31½	4	5	2	3	3	34¾	4
2NC12H	33½	4	5	2	3	3	36¾	4
2NC13H	38 <sup>1</sup> / <sub>8</sub>	5	6	3	4	4	39 <sup>1</sup> / <sub>8</sub>	5
2NC14H	41 <sup>1</sup> / <sub>8</sub>	5	6	3	4	4	44 <sup>1</sup> / <sub>8</sub>	5
2NC15H	45	5	6	3	4	4	45 <sup>1</sup> / <sub>8</sub>	5 <sup>7</sup> / <sub>8</sub>
2NC16H	47½	5	6	3	4	4	47 <sup>5</sup> / <sub>8</sub>	5 <sup>7</sup> / <sub>8</sub>

\* Bolting corresponds to ASA 125 lbs.

# installation and operation

## CONSIDERATIONS WHEN INSTALLING OR OPERATING JET PUMPS

Penberthy Jet Pumps are easy to install and operate. They need minimal maintenance since they have no moving parts. The information given here is general and intended only to provide an idea of what is involved when installing, operating or maintaining jet pumps. Complete instructions are supplied with each jet pump.

### Installation

Penberthy Jet Pumps will operate in any position. They should be installed with minimum length of piping and with as few elbows and valves as possible to limit friction losses.

### Inlet piping

Piping must be large enough to supply jet pump at maximum flow. Inlet pressure should be as specified in the performance data for the application.

### Suction piping

To insure maximum capacity and highest possible vacuum, all suction piping must be leak tight.

Jet pumps can be connected directly to the system from which gases and vapors are being pumped; however, it is recommended that an isolating valve be provided between the suction connection and the system. Operating problems on new processes will be easier to diagnose and performance will be more easily checked if an isolation valve is installed. Leak-tight gate or butterfly valves are most suitable for this application.

### Discharge piping

Piping should be equal in size to that of the jet pump. If discharge line is long, piping size should be increased to minimize the discharge head.

When using the LM, some turbulence in the discharge stream is needed to cause the jet to seal. (The LM depends upon this seal in order to draw a vacuum at the suction connection.) The needed turbulence can be provided in several ways, including:

- by installing a swing check valve or two consecutive 90° elbows in the discharge pipe.
- by terminating the discharge pipe below the surface of a liquid, such as the operating liquid reservoir or other liquid in the system.

### Start-up of steam jet pumps

When starting steam jet pumps, the steam valve should be opened slowly to enable the unit to start smoothly. All valves should then be adjusted to permit operation according to design conditions.

### Maintenance

If properly selected, Penberthy Jet Pumps will operate for extended periods without maintenance or parts replacement. Faulty operation or reduced performance, particularly on small units, may be caused by scale or foreign matter in the lines. Install suitable strainers in the inlet lines to eliminate this problem. Scale can be removed mechanically by disassembly or by chemical treatment.

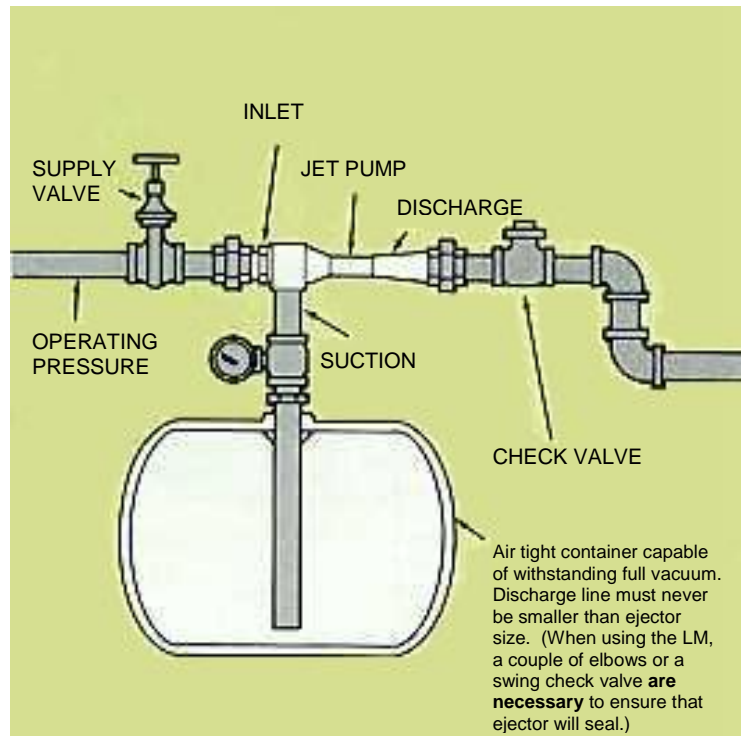

Typical jet pump installation

