

PENBERTHY

JET PUMP TECHNICAL DATA

heating liquids

This technical bulleting includes general information about Penberthy Steam Jet Heaters plus specific details for selecting the proper unit. Two series of Penberthy Steam Jet Heaters are covered in this bulleting are used for heating liquids in line. Four individual models are available for heating liquids in tanks.

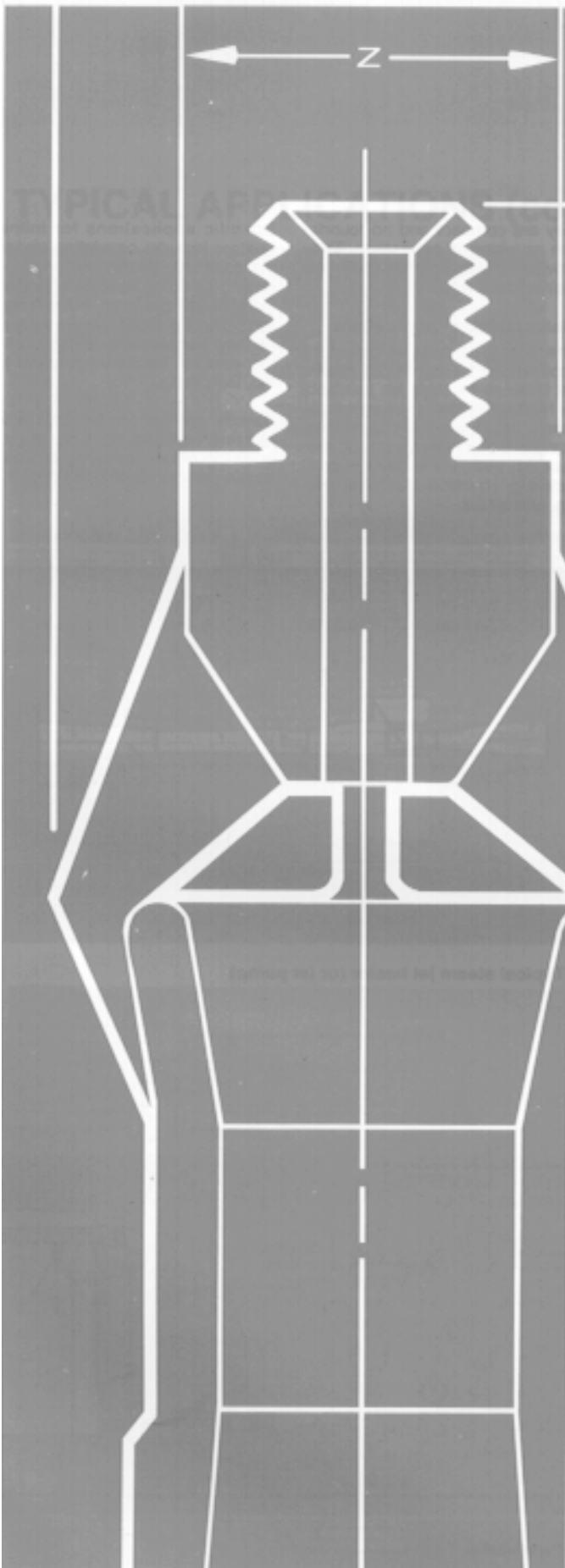

introduction and applications

Steam jet heaters optimize the condensing of steam into operating liquids to provide efficient fluid heating. They essentially are jet pumps, and as such, operate on the principle of one fluid entraining a second fluid.

Steam jet heaters have three common features (designations may vary according to design): inlet, suction and discharge.

Inlet – The operating liquid (sometimes called the Motive) under pressure enters the inlet and travels through the nozzle into the suction chamber. The nozzle converts the pressure of the operating liquid into a high velocity stream, which emerges from the discharge side of the inlet nozzle.

Suction – Pumping action begins when steam in the suction chamber is entrained by the high velocity operating liquid stream emerging from the inlet nozzle, lowering the pressure in the suction chamber. The resulting action causes the steam in the suction chamber to flow toward the discharge.

Discharge (sometimes called Outlet) – The entrained steam in the suction chamber mixes and condenses into the operating liquid and acquires part of its energy, flowing into the parallel section. In the diffuser section, part of the

velocity of the mixture is converted into a pressure greater than the suction pressure, but lower than the inlet pressure.

Stream jet heater operation

Several types of Penberthy Steam Jet Heaters are available. Although their designs vary, the operation of each is based on the jet operating principles of the jet pump.

Typically, a steam jet heater includes an inlet for the liquid to be heated, a steam inlet (suction) where steam is introduced under pressure, and a discharge where the heated liquid and condensed steam leave the heater. (These correspond to the inlet, suction and discharge of a jet pump.) Compare the cutaway illustration of a jet pump to the illustrations of jet heaters on these pages to help clarify some of the similarities between jet heaters and jet pumps.

The advantages of using steam jet heaters for heating liquids

Penberthy Steam Jet Heaters offer many advantages: They have no moving parts, nothing to break or wear.

There are no packing glands.

No lubrication is required.

The initial cost is low.

Installation cost is low because they are compact and no foundation or wiring is necessary. They provide reliable operation

with low maintenance cost.

Steam jet heater applications

There are numerous possible applications for Penberthy Steam Jet Heaters. Heaters are available for heating liquids in line or in a tank. Steam Jet Heaters are commonly found in these industries: food processing, petroleum, dairy, manufacturing, chemical, distilling/brewing, and others.

Specific applications for inline heaters include: circulating cleaning solutions, pasteurization, producing scalding sprays, sterilization, heating water, blanching, exchanging heat, degreasing, heating slurries, laundering, cooking, pickling, bonderizing, quenching and tempering.

Specific applications for open tank heaters include cooking grain, cooking mash, cooking starch, heating and circulating, mixing.

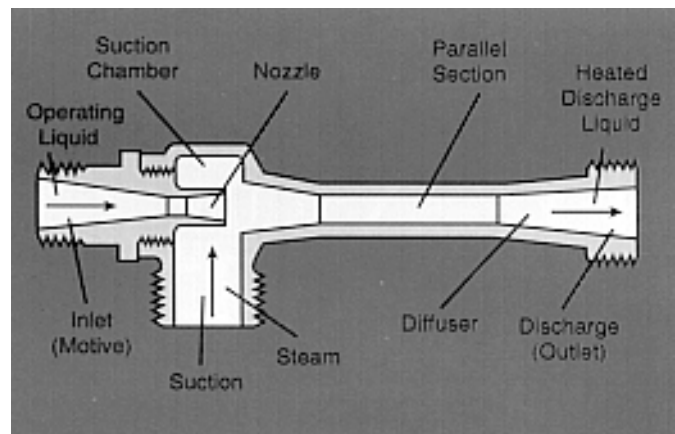

Typical steam jet heater (or jet pump)

Typical Applications

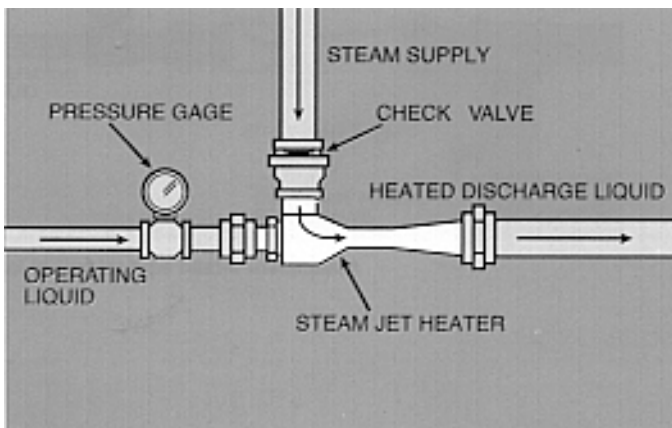

Heating liquids in line

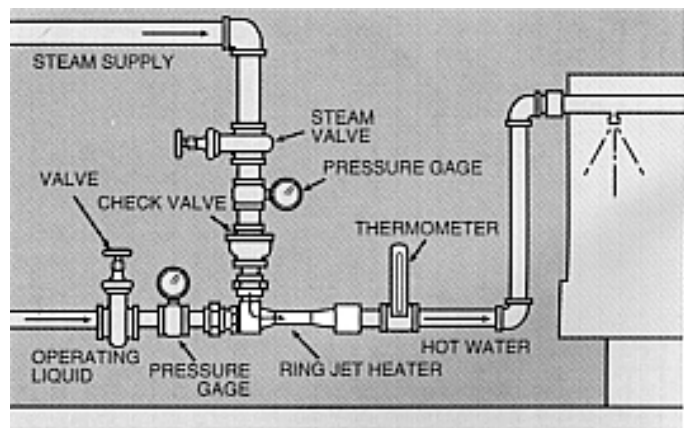

Parts washer

Typical Applications (cont.)

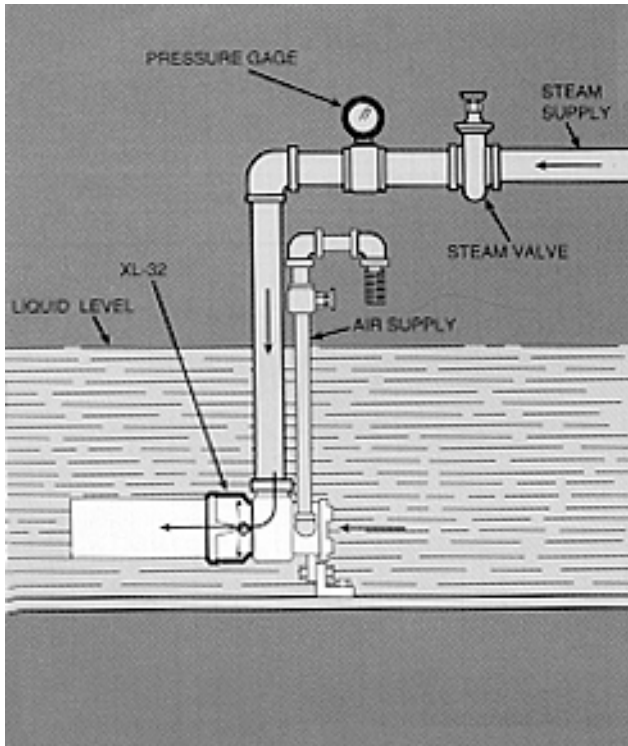

Heating liquids in open tank with XL-32 Heater

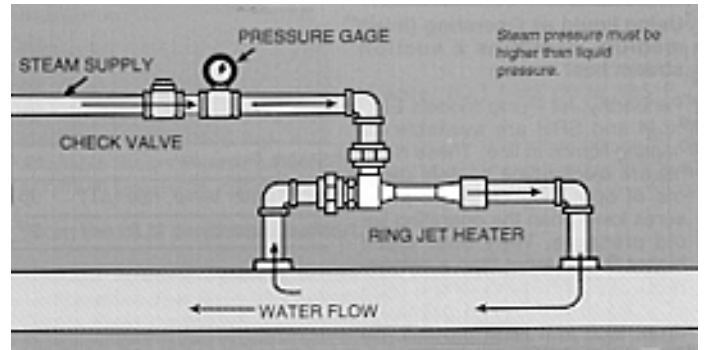

Adding small amounts of steam to a large flow of water

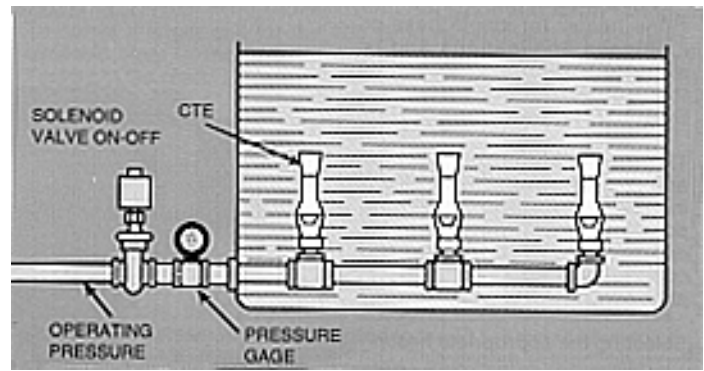

Heating liquids with Circulating Tank Educators (CTE)

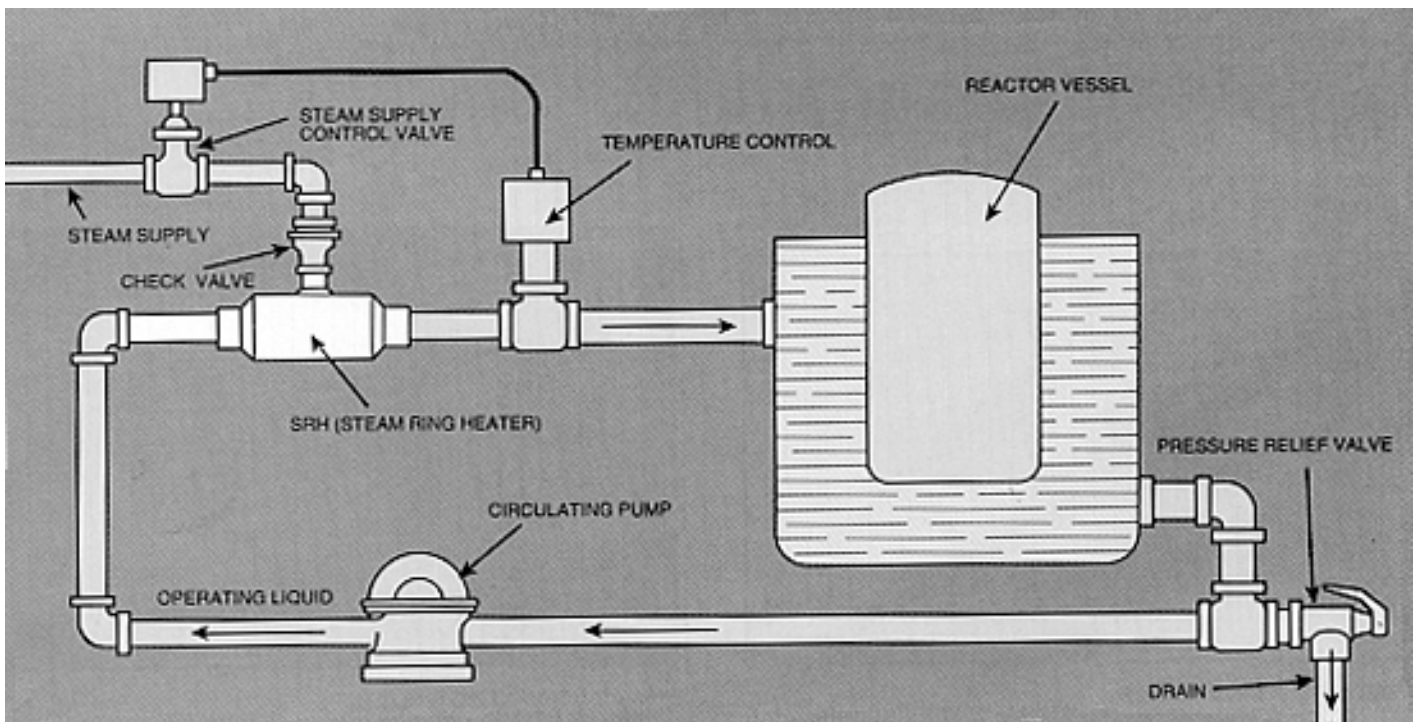

Circulating hot water system

selection

HEATING LIQUIDS IN LINE

Using liquid as Operating (Inlet) medium, steam as a suction stream heat source.

Penberthy Jet Pump models ELL, HLM and SRH are available for heating liquids in line. These models are ejector-type heaters capable of operating at steam pressures lower than the operating liquid pressure. They offer much higher BTU input than a comparable SRH, while incurring a higher inlet-to-discharge pressure drop. ELL and HLM models are typically used as single pass devices. The SRH-Steam Ring Heater is a low pressure drop inline heater for single pass or multipass applications and is available separately or as part of the automatic Fluid Heating System (FHS) package.

These inline heaters provide heat and operating pressure for cleaning solution circulation, producing scalding sprays, heating water and slurries, exchanging heat and cooking. The table lists the operating parameters of each.

Selecting the appropriate heater

To choose the appropriate inline heater for the application, compare the available steam pressure to the line pressure of the liquid to be heated. If the steam pressure is **lower** than or **equal** to the liquid pressure, and ELL or HLM heater must be used. If the steam pressure is **higher** than the liquid pressure, the ELL, HLM or SRH can be used. In this latter case, the ELL and HLM offer higher steam flows than the SRH (see table on this page). In on/off heating applications or during periods

	MODEL ELL Low Steam Pressure	MODEL HLM High Steam Pressure	SRH Low Pressure Drop	FHS Liquid Heating System
Steam Pressure	to 45 PSIG	to 120PSIG**	to 150 PSIG	to 150 PSIG
Max. w ater temp, rise(ΔT)*	up to 182 °F	up to 216 °F	up to 200 °F	up to 140 °F
Max. capacity	5000 GPM	5000 GPM	500 GPM	500 GPM

*Based on 60 °F inlet water

**M ax. steam pressure for iron body material, 60 PSIG



ELL, HLM

when steam input is halted, the ELL and HLM produce very large pressure drops. The SRH maintains its low pressure drop characteristics even when steam input is removed.

When using the HLP or ELL heater and when the discharge pressure exceeds 1/3 of the operating pressure, the heater discharge pressure should be lowered during startup, until the heater is operating, that is, until both steam and water flows are established.

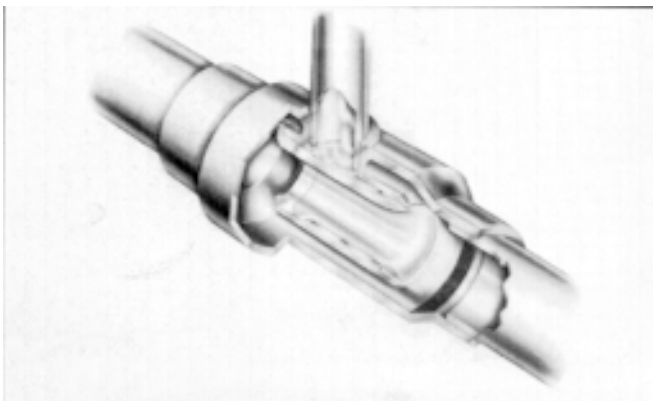

SRH (STEAM RING HEATER)

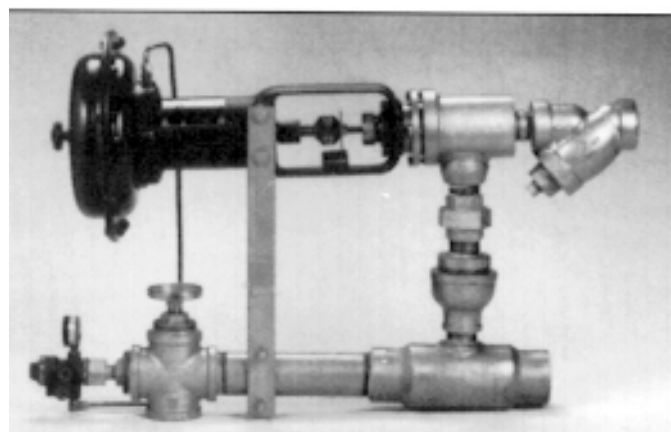

FHS (FLUID HEATING SYSTEM) 4

HEATING LIQUIDS IN LINE

The ELL and HLM heaters operate with direct connections from steam and liquid lines. Though application and performance characteristics vary between the two, steam consumption is equal for a given temperature rise. As a general rule, steam flow is calculated as follows:

Where:

$$Q_s = \frac{Q_m \Delta T}{120}$$

Q_s = steam flow in lbs/min
 Q_m = operating liquid in GPM
 ΔT = temperature rise in °F

The following general operating characteristics will help in selecting the correct model heater.

ELL operates on generally low to medium suction steam pressure (from 25" HG vacuum to 45 psig). Performance capabilities include up to 182°F temperature rise and up to 94 PSIG discharge pressure.

HLM operates over the widest range of performance characteristics and is usually the choice for most heating applications. It operates in a high steam pressure range (up to 120 PSIG), produces a high temperature rise (up to 216°F) at a high discharge pressure (up to 184 PSIG).

Heater selection using performance charts

The following information is required to select the correct model:

- Operating liquid (for liquids other than water, Consult Factory)
- Operating liquid inlet pressure PSIG (h_m)
- Desired operating liquid capacity GPM (Q_m)

- Operating liquid inlet temperature °F (Contact Factory when operating liquid inlet temperature exceeds 100°F)
- Desired temperature rise °F (ΔT)
- Available steam pressure PSIG (h_s)
- Minimum discharge pressure required PSIG (h_d)
- Quality of steam available, i.e., saturated or superheated

It is recommended to evaluate both the ELL and HLM using the following procedure, then choose the model that best fits the operating conditions.

Step 1 – Refer to Heater Performance Chart for selected model. Locate Operating Liquid (water) Pressure PSIG (h_m) for your application.

Step 2 – In this (h_m) row, read across to find the desired Temp. Rise °F and note the Steam Pressure (h_s), Disch. Press. PSIG (h_d) and liquid Flow (Q_m).

Step 3 – The performance charts indicate the capacities of 1 1/2 inch units. TO select units closest to actual requirements (one that equals or exceeds the required flow) it may be necessary to calculate several sizes other than 1 1/2 inch. Refer to the example.

Sizes available

Each of the two models is available in 15 sizes from 1/2 to 12-inch suction and discharge. Units are cast construction in 1/2 through 4-inch sizes. Sizes 4 through 12 inch are available in fabricated construction.

Example:

To heat operating liquid 100 GPM water (Q_m) from 60 to 185° (ΔT 125°F)
 Operating Liquid PSIG (h_m).....40
 Available Steam Pressure (h_s).....150
 Minimum Discharge Pressure required (h_d).....25

From the HLM performance chart:

Opposite 40 PSIG Operating Liquid Inlet Pressure (h_m) locate desired Temperature Rise (ΔT) 125°F (between 121 and 132). The required Steam Pressure (h_s) will be between 40 and 45 PSIG. The Discharge Pressure (h_d) is greater than the minimum pressure required. The Liquid Flow (Q_m) is 23 GPM which is below the requirement of 100 GPM.

To select a larger unit for the 100 GPM requirement, try the next available sizes – the 2, 2 1/2 and 3 inch units using the Capacity Factors in the chart.

- 2 inch size CF = 1.8
 Heating capacity = 23*1.8 = 41 GPM (too low)
- 2 1/2 inch size CF = 3.17
 Heating capacity = 23*3.17 = 73 GPM (too low)
- 3 inch size CF = 5.92
 Heating capacity = 23*5.92 = 136 GPM (exceeds requirements)

Repeat this procedure for the ELL

In this example, the ELL-3 comes closest to fitting the requirements. However, the steam pressure supplied to the ELL-3 would have to be throttled down from 150 PSIG to only 8 PSIG. This degree of throttling may be impractical, so the HLM-3 would be the more appropriate choice.

Cast unit connection

Units 1/2 through 3 inch in size have NPT inlet, suction and discharge connections. 4 inch size has NPT inlet and flanged suction and discharge. Flanges on cast units are flat faced with holes, sizes and spacing corresponding to 150 pound ANSI flanges.

Fabricated unit connection

All fabricated ELL and HLM units, 4 through 12 inch sizes, have flat faced flanges with holes, sizes and spacing corresponding to 150 pound ANSI flanges.

NOTE: Always specify material, model and unit size when ordering. For available materials, check **Penberthy Material Specification Sheet**.

ELL, HLM models

1 1/2 MODEL ELL HEATER PERFORMANCE CHART (WATER)

Operating Water PSIG (Inch)	Data Description	STEAM Pressure (Inch)																											
		Inches Hg. Vacuum					Pounds Per Square Inch Gage																						
		25"	20"	15"	10"	5"	5	10	15	20	25	30	35	40	45	50	55	60	65	70	75	80	85	90	95	100	105	110	115
20	Temp Rise - F° (AT)	40	60	77	100	115	126	133	140	150																			
	DISCH. PRES. - (hd)	0	0	8	10	12	14	14	14	14																			
	LIQUID FLOW - GPM (Qm)	18	18	18	16	15	15	14	14	14																			
30	°F	9	24	36	56	69	86	100	113	118	123	136	144	154															
	PSIG	0	5	8	15	18	19	20	21	21	21	22	21	21															
	GPM	21	21	21	21	20	20	19	18	18	18	17	17	16															
40	°F	11	25	36	52	65	80	90	99	105	111	126	132	143	153														
	PSIG	5	8	13	18	22	25	26	27	28	29	29	30	30	30														
	GPM	23	23	23	23	22	22	22	22	21	21	20	20	19	19														
50	°F	14	22	36	48	60	79	83	92	96	100	111	122	130	139	145	150												
	PSIG	8	10	11	19	24	27	30	31	32	34	35	36	36	37	37	37												
	GPM	25	25	25	25	25	25	24	24	24	23	23	22	22	22	21	21												
60	°F	14	22	31	43	57	71	76	84	89	94	104	112	120	128	131	134	147											
	PSIG	12	14	16	24	28	29	32	33	34	36	39	41	42	43	43	41	41											
	GPM	27	27	27	27	27	27	26	26	26	26	25	25	24	24	24	23	23											
70	°F	14	24	35	47	56	64	73	78	83	88	96	105	112	122	125	128	140	148										
	PSIG	13.5	16	18	26	30	35	38	38	39	42	44	44	44	44	44	44	44											
	GPM	29	29	29	29	29	29	29	28	28	28	27	27	27	26	26	26	26											
80	°F	10	20	32	44	54	62	68	78	80	82	90	97	104	112	115	118	127	144	150									
	PSIG	17	18	21	26	32	37	38	40	42	44	45	46	49	48	48	48	48	48										
	GPM	31	31	31	31	31	31	31	31	31	30	30	29	29	28	28	28	28	28										
90	°F	10	22	30	42	50	64	65	72	78	80	88	92	100	108	111	113	120	128	136	141								
	PSIG	20	22	23	27	35	39	42	44	46	48	50	52	53	56	56	57	58	58	58									
	GPM	32	32	32	32	32	32	32	32	32	32	32	32	31	31	31	31	30	30	29	29								
100	°F	7	17	26	40	46	66	70	72	74	80	86	92	95	99	102	106	114	120	127	134	140	144	149	154	172	182		
	PSIG	23	24	26	29	36	42	44	46	48	51	54	56	57	58	59	60	63	65	67	69	70	71	72	73	75	75		
	GPM	33	33	33	33	33	33	33	32	32	32	32	32	32	32	32	31	31	31	31	31	30	30	30	30	30	30	30	
120	°F	7	18	28	37	44	59	63	67	69	73	78	82	88	93	97	101	106	111	116	121	125	127	132	137	155	168	180	
	PSIG	28	30	32	34	37	48	51	53	54	56	59	61	64	67	68	69	71	73	76	78	80	81	82	83	86	90	90	
	GPM	36	36	36	36	36	36	36	36	36	36	35	35	35	35	35	34	34	34	33	33	33	33	32	32	32	32	32	
140	°F	6	14	24	34	43	54	58	61	63	67	74	80	84	88	91	94	99	104	108	112	114	118	124	130	140	156	168	
	PSIG	34	36	38	41	43	50	54	58	60	62	68	69	72	74	75	76	78	80	83	85	86	88	91	94	94	94	94	
	GPM	39	36	39	39	39	39	39	39	39	39	38	38	38	38	38	38	38	38	37	37	37	37	37	37	37	37	37	

CAUTION: Attempted operation within this area will cause uncondensed steam to discharge from heater.

All data based on 32-100°F operating liquid temperatures. For other temperatures, consult factor.

1 1/2 MODEL HLM HEATER PERFORMANCE CHART (WATER)

Operating Water PSIG (Inch)	Data Description	STEAM PRESSURE (Inch)																										
		Inches Hg. Vacuum					Pounds per square inch gage																					
		25"	20"	15"	10"	5"	5	10	15	20	25	30	35	40	45	50	60	70	80	90	100	110	120					
10	TEMP. RISE - F° (AT)	24	32	40	60	84	106	127	144	166																		
	DISCH. PRES. - (hd)	4	4	6	17	20	24.5	30.5	34	30																		
	LIQUID FLOW - GPM (Qm)	17	17	16	16	15	15	14	14	12																		
20	°F	15	20	26	34	61	64	80	98	107	120	134	152															
	PSIG	4	7	10	15	20	25	30	35	38	42	46	51															
	GPM	20	20	20	20	20	19	19	18	18	18	17	16															
30	°F	1	12	18	23	30	55	56	65	77	90	103	114	128	140	153	165											
	PSIG	5	7	8.5	11	15	22	27	33	37	41	45	52	55	60	65	75											
	GPM	23	23	23	23	22	23	23	22	22	22	22	22	20	20	19	18											
40	°F	4	10	14	20	27	42	54	57	67	81	91	102	121	132	144	170	190										
	PSIG	8	11	14	17	20	25	28	32	37	42	48	53	57	62	68	77	80										
	GPM	25	25	25	25	25	25	25	25	24	24	24	23	23	23	22	21	21										
50	°F	3	8	14	19	22	38	47	57	69	80	90	102	112	122	132	161	180	200									
	PSIG	12	15	17	21	23.5	30	35	40	45	50	56	64	66	70	75	85	96	101									
	GPM	28	28	28	28	28	27	27	27	26	26	26	26	25	25	24	23	23	22	22								
60	°F	2	8	12	18	22	34	44	54	64	73	82	92	100	110	120	142	162	184	204								
	PSIG	14	19	21	24	27	35	38	44	50	55	61	66	71	75	80	89	101	104	106								
	GPM	30	30	30	30	30	30	30	29	29	29	28	28	28	27	27	26	25	24	24								
70	°F	3	7	12	17	21	33	42	51	60	69	78	85	94	103	112	130	148	168	188	200							
	PSIG	18	21	25	28	31	38	43	48	53	58	65	69	73	79	85	92	104	113	122	133							
	GPM	32	32	32	32	32	32	32	31	31	31	31	30	30	30	30	29	28	27	26	26							
80	°F	4	8	12	16	20	32	40	46	55	64	71	80	90	98	106	115	142	154	165	174	212						
	PSIG	22	26	29.5	31	34	42	46	52	57	62	68	72	79	82	86	91	107	113	128	138	142						
	GPM	33	33	33	33	33	33	33	33	33	32	32	32	32	31	31	31	30	29	28	27							
90	°F	3	6	11	16	20	30	37	44	51	60	69	76	86	91	97	116	132	146	160	175	186	216					
	PSIG	27	29	33	36	38	43	51	55	61	66	72	76	81	85	90	101	112	120	131	140	144	163					
	GPM	35	35	35	35	35	35	35	35	34	34	34	34	34	34	33	33	33	32	32	31	31	29	29				
100	°F	2	6	10	14	19	30	36	41	50	56	62	70	80	87	94	108	123	140	150	164	184	196					
	PSIG	28	30	32.5	38	41	46	54																				

ELL, HLM models

ELL, HLM CAPACITY FACTOR

1/2A	1/2B	1/2	3/4	1	1 1/4	1 1/2	2	2 1/2	3	4	6	8	10	12
0.03	0.047	0.121	0.208	0.344	0.613	1.00	1.82	3.17	5.92	11.8	24	49	71	123

CAST – ELL, HLM

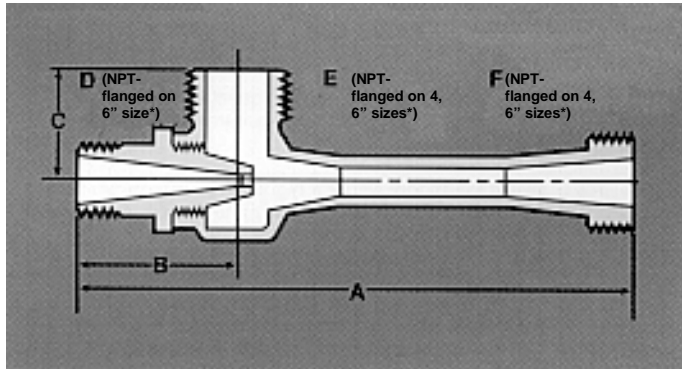

FABRICATED – ELL

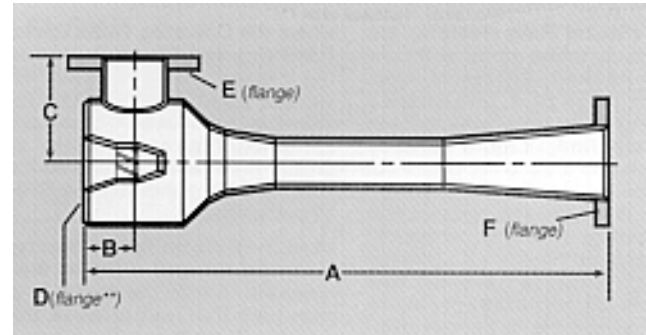

CAST – ELL, HLM DIMENSIONS (in inches)

SIZE	A	B	C	D	E*	F*
1/2A	4 3/8	1 1/2	1 1/4	1/4	1/2	1/2
1/2B	4 3/8	1 1/2	1 1/4	1/4	1/2	1/2
1/2	4 1/2	1 5/8	1 1/4	3/8	1/2	1/2
3/4	5 7/8	2	1 1/2	1/2	3/4	3/4
1	7 1/8	2 1/4	1 3/4	3/4	1	1
1 1/4	9	2 1/2	2 1/4	1	1 1/4	1 1/4
1 1/2	11	2 3/4	2 1/2	1	1 1/2	1 1/2
2	14 3/8	3 1/8	3	1 1/4	2	2
2 1/2	18 1/8	3 1/2	4 1/8	1 1/2	2 1/2	2 1/2
3	23 7/8	4	5	2	3	3
4	32 7/8	5	6	3	4 flange	4 flange

*All cast units have NPT connections except: 4 inch size has NPT inlet, flanged suction and discharge

FABRICATED – ELL DIMENSIONS (in inches)

SIZE	A	B	C	D**	E	F
4	38 1/4	5 1/4	8	3	4	4
6	52 7/8	5 7/8	9 1/2	4	6	6
8	74 7/16	8 7/16	13	6	8	8
10	87 3/8	10 3/8	14	8	10	10
12	110 3/4	11 3/4	18	10	12	12

**Inlet flanges on fabricate units have blind tapped holes.

FABRICATED - HLM

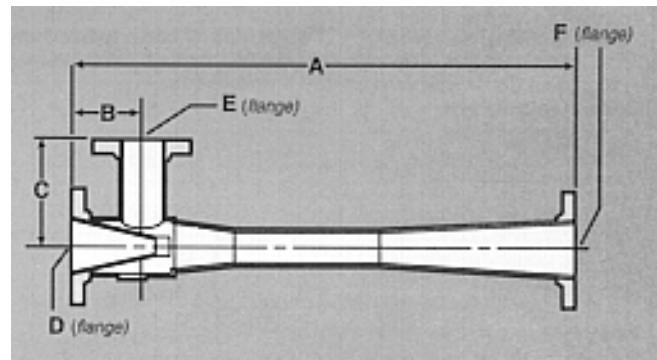

FABRICATED – HLM DIMENSIONS (in inches)

SIZE	A	B	C	D	E	F
4	38 1/4	5 1/4	8	4	3	4
6	52 7/8	5 7/8	9 1/2	6	4	6
8	74 7/16	8 7/16	13	8	6	8
10	87 3/8	10 3/8	14	10	8	10
12	110 3/4	11 3/4	18	12	10	12

model SRH

HEATING LIQUIDS IN LINE

SRH (Steam Ring Heaters) are compact, inline units with low pressure drop. SRH units inject steam through a ring-shaped opening within an enlargement in the pipeline. Liquid passes through and around the ring. Heat is introduced by the direct condensation of steam. They provide fast temperature correction noiselessly and without vibration if correctly applied. Because the liquid flow area is unrestricted, pressure drops across the heater are minimized. This will reduce the horsepower requirements for the operating liquid pump.

SRH selection using the steam consumption and performance charts.

The following information is required to select the correct model: Operating liquid (for liquids other than water, Consult Factory)

- Operating liquid inlet pressure PSIG (h_m)
- Desired operating liquid capacity GPM (Q_m)
- Operating Liquid Inlet Temperature °F (Contact Factory when operating liquid inlet temperature exceeds 100°F)
- Desired temperature rise °F (ΔT)
- Available steam pressure PSIG (h_s)
- Minimum discharge pressure required PSIG (h_d)
- Quality of steam available (i.e., saturated or superheated)
- Maximum pressure drop (ΔP). Refer to SRH (Steam Ring Heater) charts of this and the next page.

The following steps are provided for selecting the correct size SRH (Steam Ring Heater):

Step 1 – In the Steam Consumption Chart (pg. 9) locate the point where the desired Water Flow GPM and Temperature Rise in °F (ΔT) intersect. Read off the steam consumption in lbs/min.

Step 2 – In the SRH Performance Chart to the right, locate the point where the Operating Water Press. PSIG (h_m) and Steam Pressures (h_s) intersect. These represent the various steam consumptions for individual SRH units. Those con-

chart in Step 1 indicate the SRH Model to choose.

Step 3 – If steam flow shown for model selected is greater than required, throttle the steam to a pressure that will provide the required steam flow.

To determine the pressure drop for the selected unit use the formula as shown.

The Rational Flow Formula is

$$dp = \left(\frac{GPM}{C_v} \right)^2 G \quad \text{or}$$

$$GPM = C_v \sqrt{\frac{dp}{G}}$$

GPM=U.S. Gallons per minute
 C_v =Unit Flow coefficient
 G =Specific gravity
 dp = Pressure drop across the unit, PSID

C_v is defined as the number of U.S. gallons of water per minute that will flow through the unit at a 1 PSI pressure drop.

Example:
 A flow of 150 GPM water through

$$dp = \left(\frac{GPM}{C_v} \right)^2 G$$

$$dp = \left(\frac{150}{75} \right)^2 (1)$$

$$dp = 4 \text{ PSID}$$

a 320 Heater would result in what pressure drop?

Model SRH Sizes available

Model SRH (Steam Ring Heaters) from Penberthy are available in inlet and outlet sizes? 1 1/2, 2 and 3 inch threaded and 6 inch flanged.

UNIT	Cv Liquid Sizing Coefficient (GPM)	Heat Input Max. (BTU Min. @ 150 PSIG WSP)*
310	50	32,000
320	75	48,000
330	125	79,000
340	350	128,000

EXAMPLE

To heat 150 GPM water from 70 to 85°F (ΔT 15°F)
 Operating Liquid Inlet Pressure PSIG (h_m).....40
 Available Steam Pressure PSIG (h_s).....80
 Maximum pressure drop PSIG (ΔP).....5
 From Step 1 of the procedure, the steam consumption is 18.7 lb/min

From Step 2 note the steam consumption closest to 18.7. Model 310 will handle 18 lb/min, just below our requirement and Model 320 will handle 27 lb/min.

From Step 3, select the model with the higher available steam consumption and throttle the steam accordingly. The Performance Chart indicates that the Model 320 should be throttled to slightly above 60 PSIG to achieve the desired consumption of 18.7 lbs/min.

Note that the **maximum** allowable pressure drop (ΔP) is 5 PSIG in this example. Using the Rational Flow Formula example for the Model 320 selected, we see the pressure drop is 4 PSIG below the stated maximum.

SRH PERFORMANCE CHART Steam Consumption lbs/min (Q_s)

Op. Water Press.** PSIG (h_m)	Model	STEAM PRESSURE -- PSIG (h_s)											
		20	30	40	50	60	70	80	90	100	120	140	150
10	310	6	9	11	13	15	17	19	21	23	26	30	32
	320	9	14	17	20	22	25	28	31	34	40	45	48
	330	16	23	28	33	37	42	47	52	56	66	75	79
	340	25	36	45	52	60	68	75	83	90	106	121	128
20	310		7	10	13	15	17	18	21	23	26	30	32
	320		10	15	19	22	25	28	31	34	40	45	47
	330		17	25	31	37	42	47	52	56	66	75	79
	340		28	40	50	59	68	75	83	90	106	121	127
40	310				9	12	15	18	20	23	26	30	32
	320				13	18	23	27	31	34	40	45	47
	330				22	31	38	45	51	56	66	75	79
	340				35	49	61	72	82	90	106	121	127
60	310					11	15	19	21	26	30	32	
	320					16	22	28	32	39	45	47	
	330					26	37	46	53	65	75	79	
	340					42	60	74	86	104	120	126	
80	310								13	18	25	30	32
	320								20	27	37	44	47
	330								32	44	61	74	78
	340								52	71	98	119	126

All data based on 32 to 100°F inlet water temperature (T_m). For other inlet water temperatures consult factory.

** (with water flowing)

NOTE: Operation in shaded ranges is susceptible to high frequency noise.

NOTE: Always specify material, model and unit size when ordering. For available materials, check **Penberthy Material Specifications Sheet**.

*Working Steam Pressure (at operating liquid pressure of 80 PSIG)

STEAM CONSUMPTION CHART:

SRH STEAM CONSUMPTION (lbs per minute)

REALATED TO TEMPERATURE RISE AND WATER FLOW*

Water Flow GPM (Qm)	TEMPERATURE RISE IN °F (ΔT)																														
	5	10	15	20	25	30	35	40	45	50	55	60	65	70	75	80	85	90	95	100	110	120	130	140	150	160	170	180	190	200	
10	0.4	0.8	1.2	1.7	2.1	2.5	2.9	3.3	3.7	4.2	4.6	5	5.4	5.8	6.2	6.7	7.1	7.5	7.9	8.3	8.7	9.2	10	10.8	11.7	12.5	13.3	14.2	15	15.8	16.7
15	0.6	1.2	1.9	2.5	3.1	3.7	4.4	5	5.6	6.2	6.9	7.5	8.1	8.7	9.4	10	10.6	11.2	11.9	12.5	13.7	15	16.2	17.5	18.7	20	21	22	24	25	
20	0.8	1.7	2.5	3.3	4.2	5	5.8	6.7	7.5	8.3	9.2	10	10.8	11.7	12.5	13.3	14.2	15	15.8	16.7	18.3	20	22	23	25	27	28	30	32	33	
25	1	2.1	3.1	4.2	5.2	6.2	7.3	8.3	9.4	10.4	11.4	12.5	13.5	14.6	15.7	16.7	17.7	18.7	19.8	21	23	25	27	29	31	33	35	37	40	42	
35	1.5	2.9	4.4	5.8	7.3	8.7	10.2	11.7	13.1	14.6	16	17.5	18.9	20	22	23	25	26	28	29	32	35	38	41	44	47	50	52	55	58	
45	1.9	3.7	5.2	7.5	9.4	11.2	13.1	15	16.9	18.7	21	22	24	26	28	30	32	34	36	37	41	45	49	52	56	60	64	67	71	75	
60	2.5	5	7.5	10.3	12.5	15	17.5	20	22	25	27	30	32	35	37	40	42	45	47	50	55	60	65	70	75	80	85	90	95	100	
80	3.3	6.7	10	13.3	16.7	20	23	27	30	33	37	40	43	47	50	53	57	60	63	67	73	80	87	93	100	107	113	120	127	133	
100	4.2	8.3	12.5	16.7	21	25	29	33	37	42	46	50	54	58	62	67	71	75	79	83	92	100	108	117	125	133	142	150	158	167	
125	5.2	10.4	15.6	21	27	31	36	42	47	52	57	62	68	73	78	83	88	94	99	104	115	125	135	146	156	167	177	187	198	208	
150	6.2	12.5	18.7	25	31	37	44	50	56	62	69	75	81	87	94	100	106	112	119	125	137	150	162	175	187	200	212	225	237	250	
175	7.3	14.6	22	29	36	44	51	58	66	73	80	87	95	102	109	117	124	131	139	146	160	175	189	204	219	233	249	262	277	291	
200	8.3	16.7	25	33	42	50	58	67	75	83	92	100	108	117	125	133	142	150	159	167	183	200	217	233	250	267	283	300	317	333	
250	10.4	21	31	42	52	62	73	83	94	100	114	125	135	146	156	167	177	187	198	208	229	250	271	291	312	333	354	375	396	416	
300	12.5	25	39.4	50	62	74	86	100	112	124	138	150	162	175	187	200	212	225	237	250	275	300	325	350	375	400	425	450	475	500	
400	17	33	50	67	83	100	117	133	150	167	183	200	217	233	250	267	283	300	317	333	367	400	433	466	500	533	566	600	633	666	
500	21	42	62	83	104	125	146	166	187	200	229	250	271	291	312	333	354	375	396	416	458	500	541	583	625	666	708	750	791	833	

*Based on 60°F inlet water

SRH

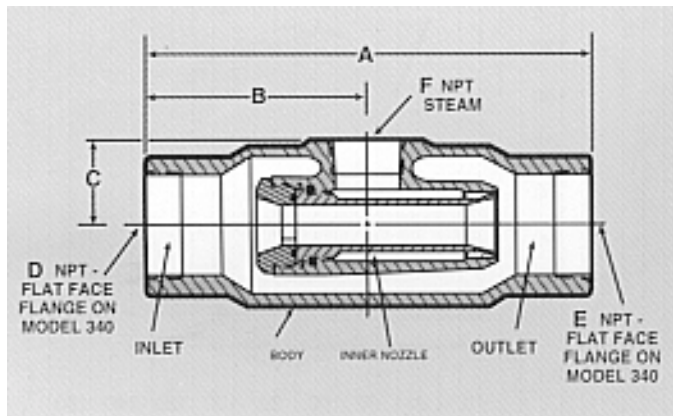

SRH DIMENSIONS (in inches)

UNIT	INLET	OUTLET	STEAM	A	B	C
310	1 1/2	1 1/2	1	6 5/8	3 3/8	1 3/4
320	2	2	1 1/4	9 3/4	4 7/8	1 7/8
330	3	3	1 1/2	10 3/4	5 3/8	2 1/2
340	6(Flgd.)	6(Flgd.)	2	10	5	3 3/4

HEATING LIQUIDS IN LINE

FHS Packaged Fluid Heating System

FHS (Automatic Fluid Heating Systems) models are complete pre-engineered systems including: heater, pneumatic temperature controller, steam flow control valve, dial thermometer, steam strainer, check valve and associated piping. The packaged system approach saves installation time and labor costs while providing flexibility and control.

Penberthy SRH (Steam Ring Heaters) are the standard models supplied in the FHS System. This system is applicable to the same liquid heating services as the SRH. All other inline ejector heaters in this catalog may be used in these automated package systems though they may require different steam pressures. Consult Factory.

The following information is required to select the correct model:

- Operating liquid (for liquids other than water, Consult Factory)
- Operating liquid inlet pressure PSIG (h_m)
- Desired operating liquid capacity GPM (Q_m)
- Operating Liquid Inlet Temperature °F (Contact Factory when operating liquid inlet temperature exceeds 100°F)
- Desired temperature rise °F (ΔT)
- Available steam pressure PSIG (h_s)
- Minimum discharge pressure required PSIG (h_d)
- Quality of steam available (i.e., saturated or superheated)

Refer to the curves for the model delivering the desired capacity and temperature rise in its operating range. Refer to the FHS Performance Chart and using the Rational Flow Formula (pg. 8), determine the model delivering the required pressure drop.

FHS PERFORMANCE DATA

UNIT	Cv Liquid Sizing Coefficient (GPM)	Heat Input Max. (BTU Min. @ 150 PSIG WSP)*
310-100	32	30,000
320-125	48	45,000
330-150	81	75,000
340-200	242	121,000

*Working Steam Pressure (at operating liquid pressure of 80 PSIG)

FHS DIMENSIONS (in inches)

MODEL	A	B	C	D	E	F	G	H
310-100	23 3/8	15 1/4	1 15/16	18 1/4	9 5/8	1	1 1/2	1 1/2
320-125	30 3/4	21 3/8	2 1/4	20 1/4	13 3/8	1 1/4	2	2
330-150	35 5/8	25 1/8	24 1/4	24 1/4	15 1/2	1 1/2	3	3
340-200	47 1/4	40	22 1/2	22 1/2	19 1/2	2	6	6

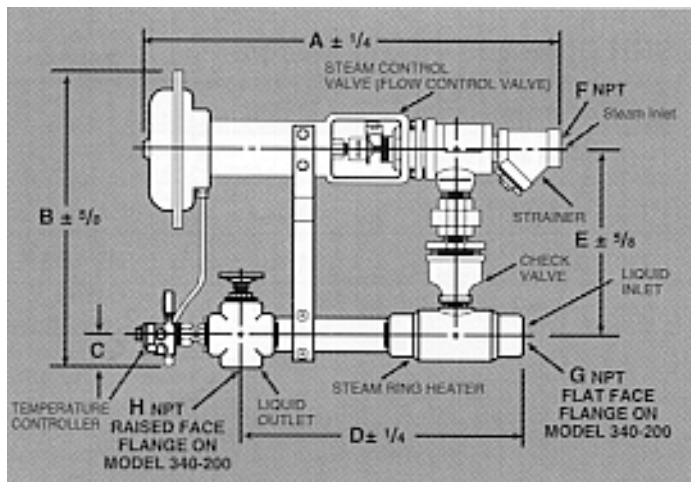

FHS PERFORMANCE CURVES

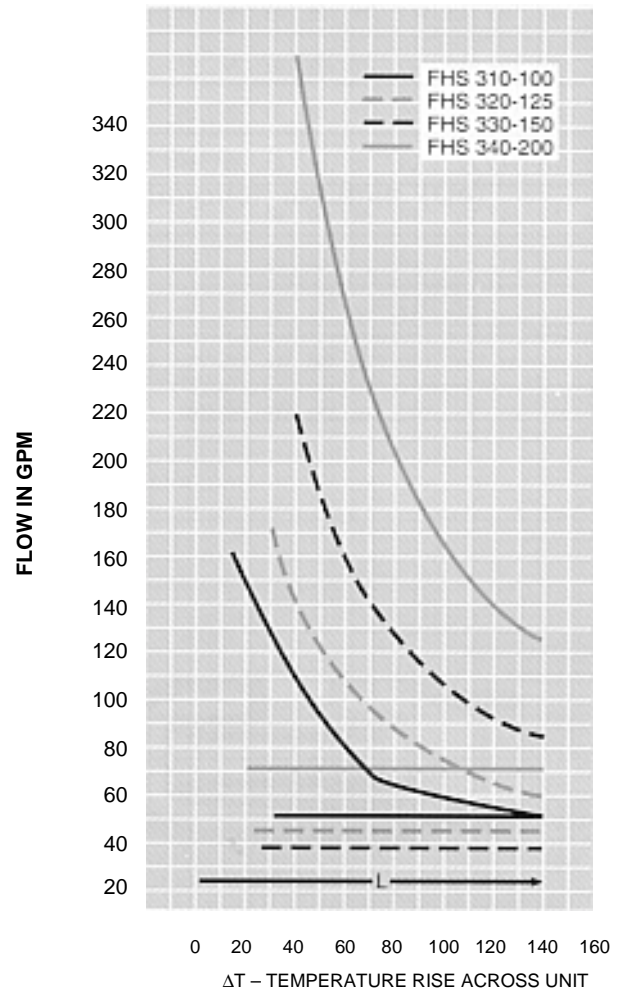

HEATING LIQUIDS IN OPEN TANKS

NWH Water Heaters, CTE Circulating Tank Eductors, XL-32 Heaters, RJ Heaters

Open tank heaters combine steam and liquid in vessels where contents may be recirculated. Open tank heaters provide circulation and efficient steam-liquid contact superior to coil heating without the noise of direct application. Open tank heaters are installed submerged in the tank.

Using up to 140 PSIG steam, Penberthy open tank heaters produce maximum temperature rises up to 120°F, depending on size of the unit. **Because of the nature of open tank installations, do**

not attempt to heat beyond the maximum stated temperature.

There are four basic Penberthy Jet models available for heating liquids in tanks: NWH, CTE, XL-32 and RJ. These submerged open tank heaters combine steam and liquid or slurry to recirculate the contents of a tank. They are especially suited for cooking, heating and circulating liquids.

NWH – an inexpensive, basic heater.

CTE – a versatile heater that can also produce a strong mixing action throughout the tank contents.

XL-32 – of the four heaters available from Penberthy, the XL-32 provides the highest steam flow for a given size of pipe. There is a

provision for admitting controlled amounts of free air to allow near noiseless operation on as little as 3 PSIG steam pressure (the NWH and CTE require a minimum of 10 PSIG steam pressure).

RJ – a two-piece construction heater designed to operate at low steam pressures in deep or shallow tanks with strong circulating actions.

MODEL	NWH WATER HEATER	CTE-CIRCULATING TANK EDUCTOR	XL-32 HEATER	RJ HEATER
Operating steam pressure	up to 120 PSIG	up to 140 PSIG	up to 140 PSIG	up to 150 PSIG
Max. water temp rise	up to 120 deg F	up to 120 deg F	up to 120 deg F	up to 120 deg F
Max. final tank temp	up to 160 deg F	up to 160 deg F	up to 160 deg F	up to 170 deg F



RJ HEATER

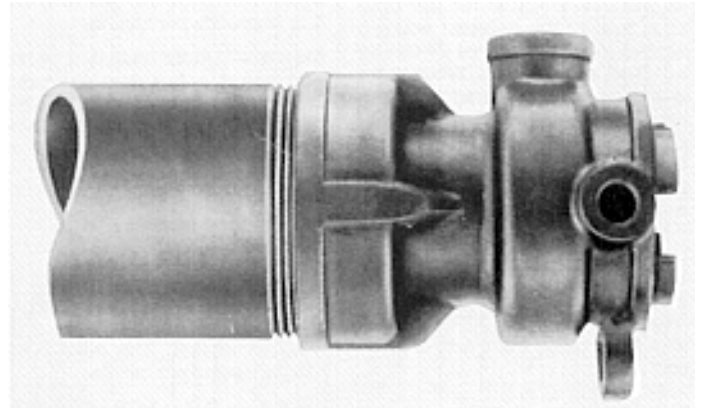

XL-32 HEATER

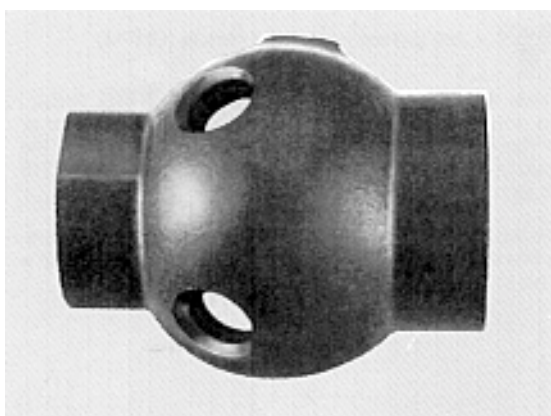

NWH WATER HEATER

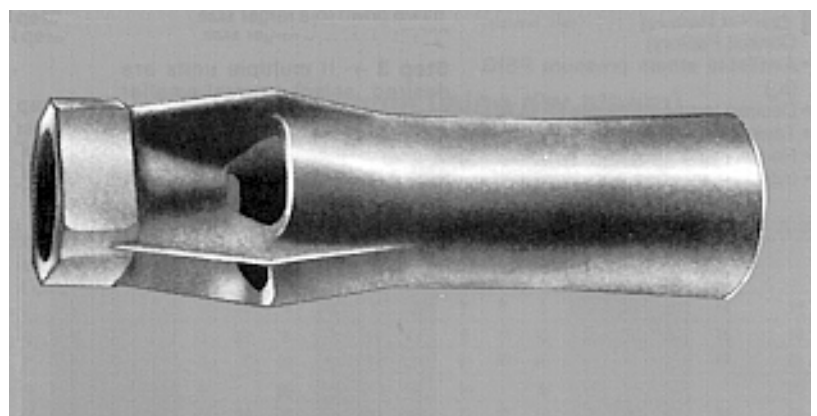

CTE - CIRCULATING TANK EDUCTOR

NWH, CTE, XL-32

HEATING LIQUIDS IN OPEN TANKS

Model NWH

NWH Heaters offer an economical method for introducing steam into a tank. Recommended for installation with 10 to 12 inch length pipe nipple, mounted away from the tank wall and aimed toward the most remote part of the tank. Inlet and steam supply sizes range from **1/4 to 2 inches**

Model CTE

The CTE (Circulating Tank Educator) is an ejector-type jet, requiring no nipple, recommended for tanks in multiple installations near and parallel to the tank bottom. Steam inlet sizes range from **3/8 to 3 inches**.

Model XL-32

The XL-32 Heater produces the highest steam flow for the pipe size, and is the quietest when a controlled amount of free air can be admitted at the nozzle. When there is a choice, the preferred operating range is 60 to 80 PSIG. The heater should be installed clear of the tank sides pointing toward the remote part of the tank and equipped with a 12 to 18 inch discharge nipple. For each PSIG of steam, the unit should be submerged no more than 3 inches. For pressures over 30 PSIG, submergence should not exceed 8 feet. The XL-32 steam inlet sizes range from **1/2 to 2 inches**.

Unit selection using performance charts

The following information is required to select and size tank heaters:

- Tank liquid (if other than water, Consult Factory)
- Available steam pressure PSIG (h_m)
- Desired temperature rise °F (ΔT)
- Tank capacity, gallons
- Heating time, minutes
- Initial temperature of liquid °F (T_s)

There are two methods provided here for selecting the correct unit. Method 1 uses the Steam Consumption Table (lb/min of steam), Method 2 uses the Performance Table (heating capacity in GHPM-gallons heated per minute).

Method 1:

Step 1 – Multiply the total batch gallons by 8.33 lbs to find the weight (if water).

Step 2 – Multiply the result by the number of degrees temperature rise desired and divide this number by 1000 to determine the weight of steam (lbs) to do the job

Step 3 – Divide this figure by the heating time required (in min.). This figure represents the rate of steam flow in pounds per minute.

Step 4 – Under available Steam Pressure, locate steam consumption equal to or greater than the requirement. At this point, move to the left and determine the unit size.

Method 2:

This method can also be used in selecting the NWH, XL-32 and the CTE heaters.

Step 1 – Divide the total batch gallons to be heated by the time (in minutes) required. This result is the gallons heated per minute.

Step 2 – Refer to the Performance Chart. In the column under required available operating Steam Pressure select the figure equal to or greater than the desired capacity. Check to determine if adequate temperature rise is possible with this size. If not, move down to a larger size.

Step 3 –If multiple units are desired, select several smaller heaters with a total capacity of that require.

NOTE: Always specify material, model and unit size when ordering. For available materials, check **Penberthy Material Specification Sheet**.

Method 1 Example:

This method can be used in selecting the NWH, the XL-32 or the CTE heaters for water.

Operating Conditions

Available Steam Pressure PSIG (h_m).....	40
Desired Temperature rise °F (ΔT).....	40
Tank capacity, gallons.....	800
Heating time, minutes.....	60
Initial temperature of liquid °F (T_s).....	40

Step 1 – 800 (gallons) x 8.33 (lbs) = 6670 lbs, the weight of water

Step 2 - $\frac{6670 * 40(\Delta T)}{1000} = 267 \text{ lbs}$ the weight of steam

Step 3 - $\frac{267 \text{ lbs}}{60 \text{ min}} = 4.45 \frac{\text{lb}}{\text{min}}$ required

Step 4 – From Steam Consumption Chart – The NWH 1 unit will handle 5 lbs/min. The CTE 3/4 unit will handle 6 lbs/min and the XL-32 will handle 7 lbs/min. In both cases, the steam may be throttled back to reduce the rate of steam consumption to the desired 4.45 lb/min.

Note: Multiple units can be used if desired. Select smaller units with total steam consumption equal to or greater than the desired flow rate obtained in Step 3.

Method 1 Example:

Though the following example illustrates the selection of a CTE heater, the same procedure can be used in selecting the NWH or XL-32 as well.

Operating Conditions

Available Steam Pressure PSIG (h_m).....	80
Desired temperature rise °F (ΔT).....	40
Tank Capacity, gallons.....	10,000
Heating time, minutes.....	35

Step 1 - $\frac{10,000}{35} = 286$ gallons heater per minute (GHPM)

Step 2 – From Performance Chart – Under 80 PSIG Steam Pressure, go down the column to the capacity that is equal to or greater than required, I a row where $\Delta T=40^\circ\text{F}$. In this case the required capacity is 286 GHPM and the closest (higher) one is 315 GHPM in a 3 inch CTE heater.

Step 3 – If multiple units are required, try several smaller heaters, for example five 1 1/2 inch units with 67 GHPM capacity: $5 \times 67=335$ GHPM total.

NWH, CTE, XL-32 PERFORMANCE CHART (gallons heated per minute - GHPM)

Size	Temperature Rise °F (DT)	OPERATING STEAM PRESSURE (hm)																							
		20 PSIG			40 PSIG			60 PSIG			80 PSIG			100 PSIG			120 PSIG			140 PSIG					
		NWH	CTE	XL-32	NWH	CTE	XL-32	NWH	CTE	XL-32	NWH	CTE	XL-32	NWH	CTE	XL-32	NWH	CTE	XL-32	CTE	XL-32				
1/4	10	11			17			22			29			34			40								
	20	5			8			11			14			17			20								
	40	3			4			5			7			8			10								
	80	1			2			3			3			4			5								
	120	1			1			2			2			3			3								
3/8	10	14	24		20	37		28	51		35	64		41	77		48	90			103				
	20	7	12		10	19		14	25		18	32		21	38		24	45			51				
	40	3	6		5	9		7	13		9	16		10	19		12	22			26				
	80	1	3		2	5		3	6		4	8		5	10		6	11			13				
	120	1	2		2	3		2	4		3	5		3	6		4	8			9				
1/2	10	22		25	35	39		47	53		60	67		71	80		83	94			108				
	20	11		12	17	19		23	26		30	34		35	40		41	48			54				
	40	5		6	9	10		12	13		15	17		16	20		21	23			27				
	80	3		3	4	5		6	7		7	8		8	10		10	12			13				
	120	2		2	3	3		4	4		5	6		6	7		7	8			9				
3/4	10	28	51	43	44	78	67		59	106	92		75	133	117		90	160	138		103	187	163	214	187
	20	14	25	21	22	39	34		29	53	46		37	67	59		45	80	69		52	94	82	107	93
	40	7	13	11	11	20	17		15	27	23		19	33	29		22	40	35		26	47	41	54	46
	80	3	6	5	5	10	8		7	13	11		9	17	15		11	20	17		13	23	20	27	23
	120	2	4	4	4	7	6		5	9	8		6	11	10		7	13	11		9	16	14	18	15
1	10	36		74	57	86	76		160	96		201	115		238	135		280							322
	20	18		37	28	58	38		80	48		100	58		119	67		140							161
	40	9		19	14	29	19		40	24		50	29		60	34		70							80
	80	4		9	7	14	9		20	12		25	15		30	17		35							40
	120	3		6	5	10	6		13	8		17	10		20	11		23							27
1 1/4	10	46		127	71	198	97		271	123		344	147		406	169		480							552
	20	23		64	36	99	49		135	61		172	74		204	84		240							276
	40	11		32	18	49	24		68	31		86	37		101	42		120							138
	80	6		16	9	25	12		34	15		43	18		51	21		60							69
	120	4		11	6	16	8		23	10		29	12		34	15		40							46
1 1/2	10	57	103	171	89	158	268		120	215	364		151	270	463		182	324	550		210	380	648	434	742
	20	28	51	85	44	79	134		60	107	182		75	135	232		91	162	275		105	190	324	217	371
	40	14	26	43	22	40	67		30	54	91		38	67	116		45	81	137		52	95	162	108	186
	80	7	13	21	11	20	33		15	27	46		19	34	58		23	41	69		26	48	81	54	93
	120	5	9	14	7	13	22		10	18	30		13	23	39		15	27	46		18	32	54	36	62
2	10	91	203	257	142	214	401		192	425	545		242	534	696		292	642	825		320	752	972	859	1115
	20	45	102	128	71	157	201		96	212	272		121	267	348		145	321	412		160	376	486	429	557
	40	23	51	64	35	78	100		48	106	136		60	133	174		73	160	206		80	188	243	215	278
	80	12	25	32	18	39	50		24	53	68		30	67	87		36	80	103		40	94	121	107	139
	120	9	17	21	12	26	33		18	35	45		22	44	58		27	54	68		30	63	81	72	93
3	10			481			741			1004			1261			1517			1777						2029
	20			240			371			502			631			758			888						1015
	40			120			185			251			315			379			444						507
	80			60			93			125			158			190			222						254
	120			40			62			84			105			126			148						169

NWH, CTE, XL-32 STEAM CONSUMPTION CHART (lbs per minute using dry steam)

Heater Size	OPERATING STEAM PRESSURE (hm)																											
	3 PSIG		5 PSIG		10 PSIG		20 PSIG		40 PSIG		60 PSIG		80 PSIG		100 PSIG		120 PSIG		140 PSIG									
	NWH	CTE	XL-32	NWH	CTE	XL-32	NWH	CTE	XL-32	NWH	CTE	XL-32	NWH	CTE	XL-32	NWH	CTE	XL-32	NWH	CTE	XL-32	CTE	XL-32					
1/4						1			1			2			3			4										
3/8						1	1		1	2		2	3		3	4		3	5		4	6		5	7		8	
1/2			1		1	2	2	2	2	3	4	4	4		6	7	7	8	8		8	9		9	10			
3/4			2		3	2	2	3	3	4	4	4	6	7	6	9.5	9	7	11	11	8	13	13	10	16	16	18	18
1			4		4	2	5	3	7	5	11	7	16	9	20	11	23	13	27	13	27	13	27	31		31		
1 1/4			7		7	3	9	4	13	7	19	9	26	12	33	14	38	16	46	16	46	16	46	53		53		
1 1/2			9		10	4	12	5	17	8	26	11	35	14	42	17	53	20	62	20	62	20	62	71		71		
2			13		15	6	18	9	26	13	36	16	46	18	53	23	67	27	81	27	81	27	81	93		93		
3						20			40			62			86			105			126			148		169		

HEATING LIQUIDS IN OPEN TANKS

The RJ (Ring Jet) Heater is designed to operate at steam pressures from 5 to 50 PSIG above submergence (tank pressure). Depending on steam pressure and submergence depth, the RJ can achieve final tank temperatures ranging from 145°F to 170°F.

Threaded connections on the RJ allow heater installation in a loop outside tank. Connection sizes: **1 to 3 inches.**

Unit selection using performance charts

As with selecting NWH, CTE and XL-32 units, the following information is required to select and size Model RJ Heaters:

- Tank liquid (if other than water, Consult Factory)
- Available steam pressure PSIG (H_m)
- Desired temperature rise °F (ΔT)
- Tank capacity, gallons
- Heating time, minutes
- Initial temperature of liquid (T_s)

The following steps are provided for selecting the correct size RJ Heater:

Step 1 – Determine the weight of the water to be heated by multiplying the total batch gallons by 8.33.

Step 2 – Multiply the water weight by the number of desired degrees temperature rise, and divide the result by 1000 to determine the weight of steam (lbs) required to provide efficient operation.

Step 3 – Divide the weight of steam by the heating time (in minutes) required for your application. The result is the required steam flow rate in pounds per minute.

Step 4 – use the charts here to determine the RJ steam consumption requirement. Simply locate the point where submergence depth (tank pressure) and steam pressure PSIG (h_m) intersect.

Step 5 – Select the RJ size with a steam flow equal to or greater than the steam flow rate calculated in Step 3.

Step 6 – Compare the maximum final temperature shown in Step 4 to the desired final tank temperature. If the required temperature exceeds the recommended limit, increase submergence or choose a larger RJ to operate at a lower steam pressure.

Note: For higher final tank temperatures, contact factory.

Example:

This method must be used to select the RJ Heater.

Operating Conditions

Available Steam Pressure PSIG (h _m).....	10
Desired Temperature Rise °F (ΔT).....	60
Tank capacity, gallons.....	2000
Heating time, minutes.....	120
Initial temperature of liquid °F (T _s).....	100

Step 1 – 2000 (gallons) x 8.33 (lbs) = 16600 lbs, the weight of water

Step 2 - $\frac{16,600 * 60(\Delta T)}{1000} = 999.6 \text{ lbs}$ the weight of steam

Step 3 - $\frac{999.6 \text{ lbs}}{120 \text{ min}} = 8.33 \frac{\text{lb}}{\text{min}}$ steam consumption

Step 4 – Since the submergence depth (or tank pressure) was not specified for the sample problem, refer to the 1.0 ft submergence data for a start.

Step 5 – From the RJ Steam Consumption chart – the RJ 2 1/2 will handle 12 lbs/min, which is in excess of the required 8.33 lbs/min. In this case, the steam could either be throttled to the required flow or the tank contents allowed to reach final temperature sooner than required.

Step 6 – The maximum final tank temperature attainable without cavitation for the stated operating conditions is 156°F. Since the desired final temperature (T_s) 100°F plus (ΔT) 60°F temperature rise = 160°F, either throttle the steam pressure or submerge the jet heater to 5 ft.

NOTE: Multiple units can be used if desired. For example, seven size 1 RJ Heaters will flow 7 x 1.3 lbs/min (from the chart) = 9.1 lbs/min.

RJ STEAM CONSUMPTION (lbs per minute using dry steam)

Submergence in Tank (ft. of water)	Heater Size	Operating Steam Pressure (h _m)						
		5 PSIG	10 PSIG	15 PSIG	20 PSIG	30 PSIG	40 PSIG	50 PSIG
1	1/2	0.36	0.47	0.56	0.64	0.81	0.98	1.2
	3/4	0.62	0.81	0.96	1.1	1.4	1.7	2
	1	1	1.3	1.6	1.8	2.3	2.8	3.3
	1 1/4	1.8	2.5	2.8	3.2	4.1	5	5.9
	1 1/2	3	3.9	4.6	5.3	6.7	8.1	9.6
	2	5.5	7.1	8.4	9.6	12	15	17
	2 1/2	9.5	12	15	17	21	26	30
	3	18	23	27	31	40	48	57
	MAX °F	165	156	154	152	150	147	145
	5	1/2	0.47	0.56	0.64	0.81	0.98	1.2
3/4		0.81	0.96	1.1	1.4	1.7	2	
1		1.3	1.6	1.8	2.3	2.8	3.3	
1 1/4		2.5	2.8	3.2	4.1	5	5.9	
1 1/2		3.9	4.6	5.3	6.7	8.1	9.6	
2		7.1	8.4	9.6	12	15	17	
2 1/2		12	15	17	21	26	30	
3		23	27	31	40	48	57	
MAX °F		161	159	157	155	152	150	
10		1/2	0.47	0.56	0.64	0.81	0.98	1.2
	3/4	0.81	0.96	1.1	1.4	1.7	2	
	1	1.3	1.6	1.8	2.3	2.8	3.3	
	1 1/4	2.5	2.8	3.2	4.1	5	5.9	
	1 1/2	3.9	4.6	5.3	6.7	8.1	9.6	
	2	7.1	8.4	9.6	12	15	17	
	2 1/2	12	15	17	21	26	30	
	3	23	27	31	40	48	57	
	MAX °F	166	164	162	160	157	155	
	15	1/2	0.47	0.56	0.64	0.81	0.98	1.2
3/4		0.81	0.96	1.1	1.4	1.7	2	
1		1.3	1.6	1.8	2.3	2.8	3.3	
1 1/4		2.5	2.8	3.2	4.1	5	5.9	
1 1/2		3.9	4.6	5.3	6.7	8.1	9.6	
2		7.1	8.4	9.6	12	15	17	
2 1/2		12	15	17	21	26	30	
3		23	27	31	40	48	57	
MAX °F		171	169	167	165	162	160	
10		1/2	0.52	0.64	0.81	0.98	1.2	
	3/4	0.89	1.1	1.4	1.7	2		
	1	1.5	1.8	2.3	2.8	3.3		
	1 1/4	2.6	3.2	4.1	5	5.9		
	1 1/2	4.3	5.3	6.7	8.1	9.6		
	2	7.8	9.6	12	15	17		
	2 1/2	14	17	21	26	30		
	3	25	31	40	48	57		
	MAX °F	177	175	173	170	168		
	20	1/2			0.81	0.98	1.2	
3/4				1.4	1.7	2		
1				2.3	2.8	3.3		
1 1/4				4.1	5	5.9		
1 1/2				6.7	8.1	9.6		
2				12	15	17		
2 1/2				21	26	30		
3				40	48	57		
MAX °F				195	193	191		
30		1/2				0.98	1.2	
	3/4				1.7	2		
	1				2.8	3.3		
	1 1/4				5	5.9		
	1 1/2				8.1	9.6		
	2				15	17		
	2 1/2				26	30		
	3				48	57		
	MAX °F				216	214		
	40	1/2					1.1	
3/4						1.9		
1						3.2		
1 1/4						5.7		
1 1/2						9.3		
2						17		
2 1/2						29		
3						55		
MAX °F						237		

NWH, CTE, XL-32, RJ models

NWH DIMENSIONS (in inches)

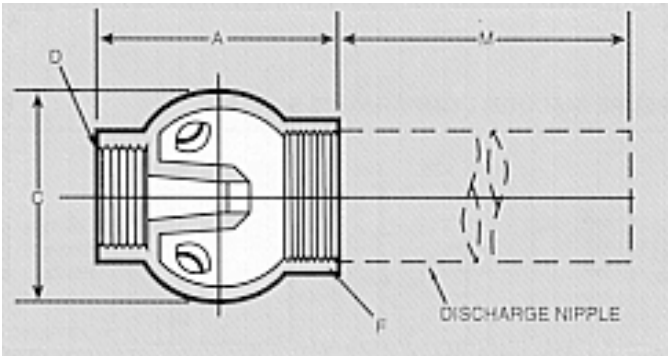

Heater Size	A	C	D	F	M
1/4	1 3/4	1 1/2	1/4	3/8	10
3/8	2 1/2	2	3/8	1/2	10
1/2	2 5/8	2 1/8	1/2	1	10
3/4	2 7/8	2 1/4	3/4	1	10
1	2 7/8	2 3/8	1	1 1/4	12
1 1/4	3 5/8	2 3/4	1 1/4	1 1/4	12
1 1/2	4 1/8	3 3/8	1 1/2	2	12
2	4 7/8	3 3/8	2	2 1/2	12

CTE DIMENSIONS (in inches)

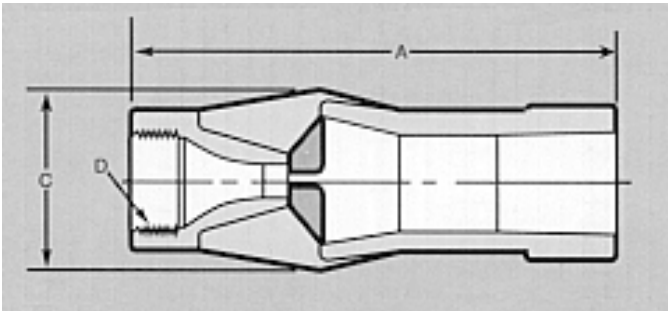

Heater Size	A	C	D
3/8*	4 1/2	1 3/4	3/8
3/4*	6	2 1/4	3/4
1 1/2	7 1/4	3	1 1/2
2	11 1/4	4 1/4	2
3	19 3/8	6 1/2	3

*Male NPT

XL-32 DIMENSIONS (in inches)

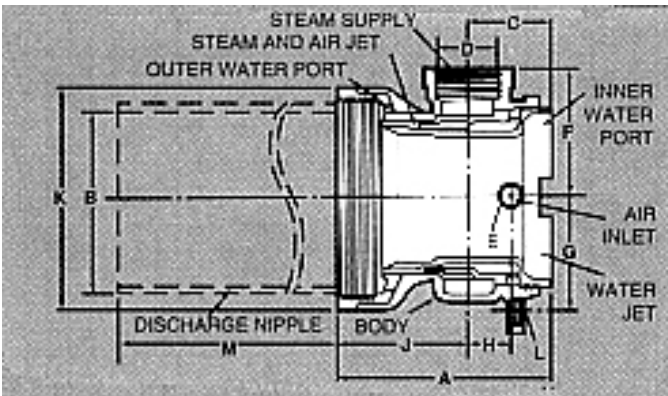

Heater Size	A	B*	C	D*	E*	F	G	H	J	K	L*	M
1/2	4 1/4	2	1 1/2	1/2	1/4	1 7/8	1 1/2	7/8	2 3/4	2 3/4	1/4	App. 12
3/4	4 1/2	2 1/2	1 5/8	3/4	1/4	2 1/8	1 3/4	7/8	2 7/8	3 1/4	1/4	App. 12
1	5	3	1 3/4	1	1/4	2 1/2	2	1	3 1/4	4	1/4	App. 12
1 1/4	5 1/2	4	2	1 1/4	1/4	2 7/8	2 1/2	1 1/8	3 1/2	5	3/8	App. 12
1 1/2	6	5	2 3/8	1 1/2	1/4	3 5/8	3 1/4	1 1/4	3 3/4	6	3/8	App. 18
2	6 3/4	7	2 3/4	2	3/8	4 3/4	4 1/4	1 5/8	4 1/8	8 1/4	3/8	App. 18

*NPT nominal pipe size

RJ DIMENSIONS (in inches)

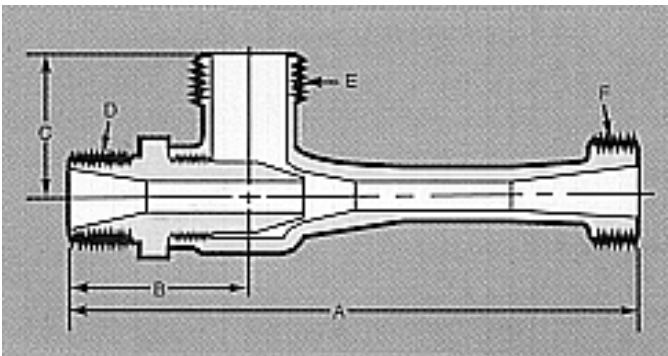

Heater Size	A	B	C	D	E	F
1	7 1/8	2 1/4	1 3/4	3/4	1	1
1 1/4	9	2 1/2	2 1/4	1	1 1/4	1 1/4
1 1/2	11	2 3/4	2 1/2	1 1/4	1 1/2	1 1/2
2	14 3/8	3 1/8	3	1 1/2	2	2
2 1/2	18 1/8	3 1/2	4 1/8	2	2 1/2	2 1/2
3	23 7/8	4	5	2	3	3

installation and operation

CONSIDERATIONS WHEN INSTALLING OR OPERATING STEAM JET HEATERS

Penberthy Steam Jet Heaters are easy to install and operate. Here are some general guidelines to installing, operating and maintaining steam jet heaters. Complete instructions are supplied with each heater.

Installation

Penberthy Steam Jet Heaters will operate in any position. However, the steam jet inlet should point upward to help rid the steam line of condensation at start-up. The use of piping, elbows and valves should be minimal to limit friction losses. Support piping to avoid putting stress on the steam jet heater.

Inlet and steam piping

Piping must be large enough to supply the heater under maximum flow conditions. Pressures should be as specified in the performance data for the application **when measured at the heater.**

Discharge piping

Piping size should be equal to that of the heater. With long discharge lines, pipe size should be increased to minimize the discharge

head. If a valve is used in the discharge line to reduce pressure during start-up, the valve outlet can be connected to a drain. It can also be connected to a tank in the process or returned to the suction side of the pump supplying liquid pressure.

Start-up steam jet heaters

Steam should be adjusted to the full required pressure. When the desired temperature has been reached, steam pressure should be shut off completely (rather than throttled) to avoid hammer. If the heater is thermostatically controlled, the steam flow should not be throttled past the recommended operating level. A snap-acting on-off steam control valve should be used.

Maintenance

When properly selected, Penberthy Steam Jet Heaters will operate for extended periods without maintenance. Faulty operation or reduced performance may be caused by scale or foreign matter in the lines. Installing strainers in the inlet lines can thus help improve performance.

PRESSURE/VACUUM COMPARATIVE SCALES

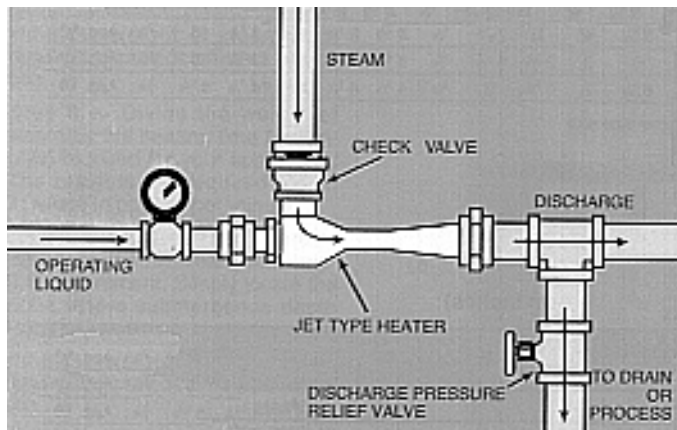
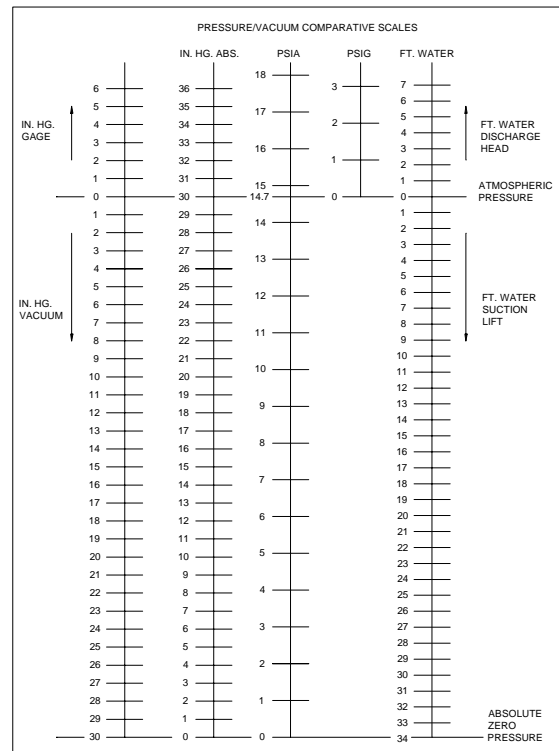

Typical in-line jet type heater installation

Unit conversions

1 kPa = 0.145 PSIG	1 kg/hr = 2.205 lb/hr
= 0.335 ft water (20°C)	1 kg/cm ³ = 28.96 in Hg (20°C)
= 0.295 in Hg (20°C)	1 W = 0.0568 BTU/min
1 cm = 0.394 in	1 l = 0.2642 gal
1 m ³ /min = 264.2 GPM	1°C = (°F-32)÷1.8

PENBERTHY

320 Locust Street, Prophetstown, IL 61277-1177 USA
 TEL: (815) 537-2311 FAX: (815) 537-5764